

# Scambiatori Aria-olio Serie HPV

*Air-oil heat-exchangers  
HPV Series*

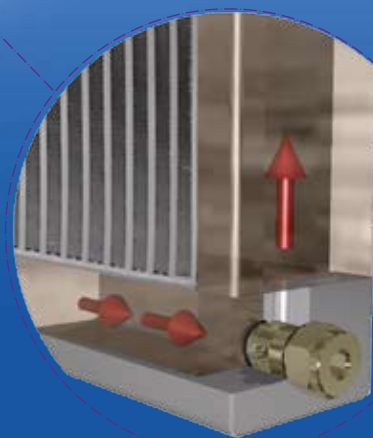

**EMMEGI**

Gli scambiatori di calore aria-olio EMMEGI, sono impiegati per il raffreddamento di circuiti oleodinamici usando, come fluido raffreddante, l'aria ambiente convogliata sulla radiante da una ventola azionata da un motore elettrico o idraulico. La massa radiante, in lega d'alluminio ad alta resistenza, è ottenuta mediante un processo costruttivo di saldobrasatura sottovuoto. La particolare configurazione dei condotti aumenta la turbolenza del fluido e di conseguenza la capacità di scambio; inoltre la presenza di speciali turbolatori sull'alettatura del pacco radiante, migliora ulteriormente il coefficiente di trasmissione totale. Il risultato è un prodotto tecnologicamente avanzato di dimensioni contenute, leggero e robusto. Gli scambiatori aria-olio serie HPV- nascono dalle esigenze applicative ad ampio raggio espresse dal mercato. Punto di forza di questi prodotti è rappresentato dal by-pass integrato che ne amplifica la semplicità d'uso, eliminando la necessità di dovere aggiungere da parte del cliente una valvola autonoma, assicurando così elevata funzionalità.

*EMMEGI air-oil heat exchangers are used for cooling oil hydraulic systems using as the coolant ambient air that passes over the radiant by means of a fan operated by an electric or hydraulic motor. The cooler element, in high resistance aluminium alloy, is obtained by means of a braze-welding process carried out under vacuum. The particular configuration of the cooling pipes increase the turbulence of the fluid consequently of the exchange capacity; moreover, the presence of special jets on the cooler finning further improves the total transmission coefficient. The result is a very small, light and robust technologically advanced product. The air-oil heat-exchangers HPV Series were born to answer the large application needs of the market. The main characteristic of this new products is the integrated by-pass valve that will simplify their employ and will avoid the customers to add an external and independent valve. This will guarantee a very high efficiency.*

## Fluidi compatibili

- . OIL MINERALI, HL, HLP.
- . EMULSIONI ACQUA-OLIO
- . ACQUA-GLICOLE
- . Per altri fluidi consultare EMMEGI.

## Compatible fluids

- . MINERAL OILS; HL; HLP.
- . WATER-OIL EMULSION.
- . WATER-GLYCOL.
- . Consults EMMEGI for other fluids.

## Specifiche tecniche Masse Radianti

- . Materiale: alluminio "long life".
- . Pressione d'esercizio: 20 bar.
- . Pressione di collaudo: 35 bar.
- . Temperatura max d'esercizio: 120°C
- . Per particolari atmosfere aggressive consultare l'EMMEGI.

## Technical specification of Cooler Element

- . Material: "long life" aluminium.
- . Operating pressure: 20 bar
- . Test pressure: 35 bar.
- . Max operating temperature: 120°C.
- . For specially "aggressive" atmospheres contact EMMEGI.

## Installazione

Lo scambiatore può essere montato in posizione orizzontale o verticale, rispettando la distanza minima dalla parete ( vedi fig. 1 ), in modo da assicurare un naturale afflusso e deflusso dell'aria di raffreddamento.

Lo scambiatore è installato di norma, sulle tubazioni di ritorno dell'olio del serbatoio; deve inoltre essere protetto da urti e vibrazioni meccaniche mediante supporti e collegato all'impianto con tubazioni flessibili. È necessario evitare che sia sottoposto a brusche variazioni di portata, colpi d'ariete e pulsazioni continue che danneggiano in modo irreversibile la radiante.

## Installation

*The exchangers can be fitted in a horizontal position, respecting the minimum distance from the wall (see fig.1) so as to ensure a natural flow of cooling air. The exchangers is usually installed on oil tank return piping; it must also be protected from impacts and mechanical vibrations by supports and must be connected to the plant with flexible pipes. Avoid subjecting the exchanger to sudden changes in flow, hammering and pulsations that can cause irreversible damage to the element.*

## Manutenzione

È buona norma prestare particolare attenzione alla pulizia della massa radiante per garantire un naturale ricambio d'aria, ed evitare una diminuzione dell'efficienza termica.

## Pulizia lato olio

Per eseguire la pulizia lato olio, lo scambiatore dovrà essere smontato. Lo sporco può essere rimosso flussando in controcorrente un prodotto sgrassante, compatibile con alluminio. Effettuate un lavaggio con olio idraulico prima di ricollegare il prodotto all'impianto.

## Pulizia lato aria

La pulizia lato aria può essere effettuata con aria compressa o acqua, con direzione del getto parallelo alle alette per non danneggiare. Lo sporco oleoso o grasso può essere rimosso con getto di vapore o acqua calda. Durante questa operazione, il motore elettrico non deve essere collegato alla tensione, e dovrà essere adeguatamente protetto.

## Esempio di scelta dello scambiatore

Per effettuare la scelta dello scambiatore si procede come segue:

Potenza da dissipare : 19,5 [KW]  
Portata olio ISO VG 32 : 90 [lpm]  
Temperatura ingresso olio : 60 [°C]  
Temperatura ambiente : 30 [°C]  
Ventola azionata da motore elettrico 230/400V-50Hz.

Si calcola la potenza specificata di scambio espressa in KW/°C, conoscendo la potenza da dissipare e il  $\Delta T$  (differenza tra la temperatura olio ingresso e la temperatura ambiente).

$$P = \frac{19.5 \text{ KW}}{60^\circ - 30^\circ} = 0.65 \text{ KW/}^\circ\text{C}$$

Nota la portata olio (90 lpm) e la potenza specifica di scambio (0.65 KW/°C) si procede alla ricerca del prodotto avvalendosi dei grafici riportati a catalogo, relativi ai singoli modelli.

## Maintenance

You should be particularly carefully in cleaning the cooler element to guarantee a natural exchange of air, in order to prevent a reduction in thermal efficiency

## Cleaning oil side

The exchanger should be dismantled to clean on the oil side. The dirt can be removed by flushing, in counter-current, de-greasing substance, compatible with aluminium. Wash with hydraulic oil before re-connecting the product to the plant.

## Cleaning air side

Cleaning on the air side can be done using compressed air or water, directing the jet parallel to the fins so as not to damage them. Oily dirt or grease can be removed with a jet of steam or hot water. During this operation, the electric motor must be disconnected from the voltage supply, and must be adequately protected.

## Example of how to choose a heat exchanger

Proceed with sizing the exchanger, with a knowledge of the data as the example below shows:

Power to dissipate : 19,5 [KW]  
ISO VG 32 oil flow : 90 [lpm]  
Oil input temperature : 60 [°C]  
Ambient temperature : 30 [°C]  
Fan operating with an electric motor 230/400V-50Hz.

You can then calculate the specific heat exchange power KW/°C if you know the power to dissipate and the  $\Delta T$  (the difference between the oil input temperature and the ambient temperature).

$$P = \frac{19.5 \text{ KW}}{60^\circ - 30^\circ} = 0.65 \text{ KW/}^\circ\text{C}$$

Note the oil flow (90 lpm) and specific exchange power (0.65 KW/°C), product research is made by referring to the graph in the catalogue which is relevant to each model.

# Dati tecnici Technical Data



P/N	V	Hz	kW	A	rpm	ø Fan	dB(A)	(m³/h)	IP	lt	Kg
2V3003###	230-400 AC B14	50/60	0,750	1,8	1450	450	82	4000	55	1,6	37
2V3012###	12 DC	/	0,150	9,5	3100	280	74	1550	68		32
2V3024###	24 DC	/	0,150	5,6	3100	280	78	1700	68		32
2V3056###	Prepared for Gr.2 hydraulic monitor					450			/		35

Per il 12-24V i dati sono riferiti al singolo ventilatore For 12-24V the data refers to each ventilator

Contattare EMMEGI Contact EMMEGI

## Diagramma rendimento Performance diagram

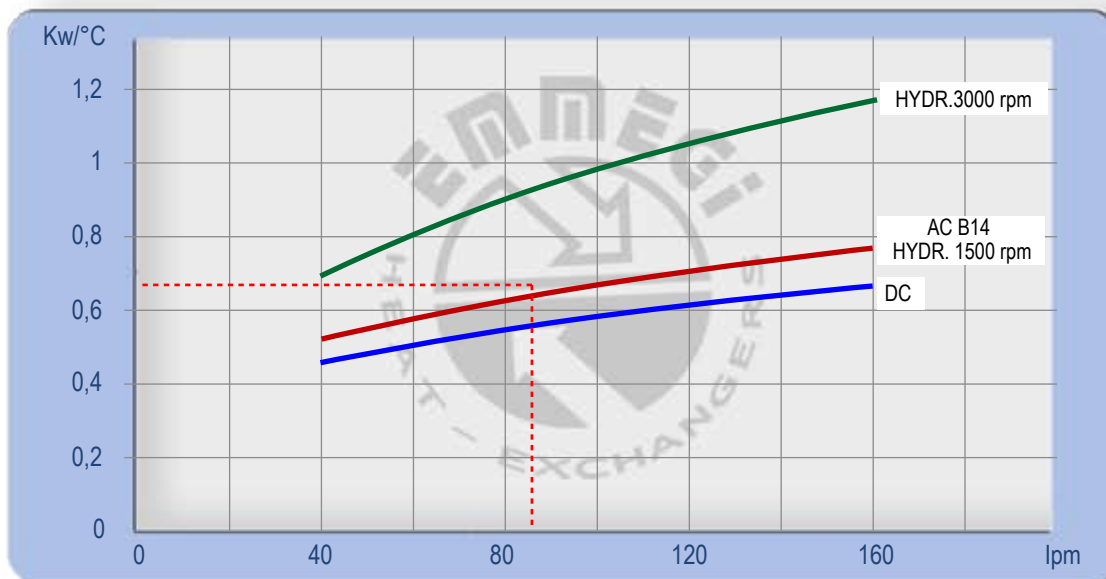

Lo scambiatore selezionato risulta il modello:  
HPV 30 - 230/400 - 50Hz  
cod. 2V3003###.

*The exchanger selected is the following model:  
HPV 30 - 230/400V - 50Hz  
cod. 2V3003###.*

Per la completa identificazione dello scambiatore consultare la pagina "DENOMINAZIONE CODICE PRODOTTO". Nel caso non siano conosciuti tutti i dati, per la scelta prendere contatto **EMMEGI**.

*For a complete description of the exchanger consult the "PRODUCT ORDERING CODE" page. If you do not know all the data required for selecting the model, contact EMMEGI.*

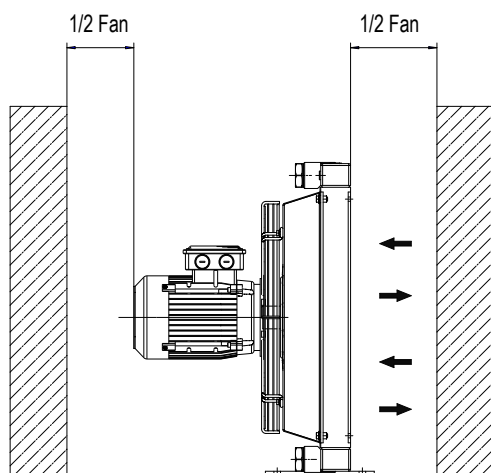
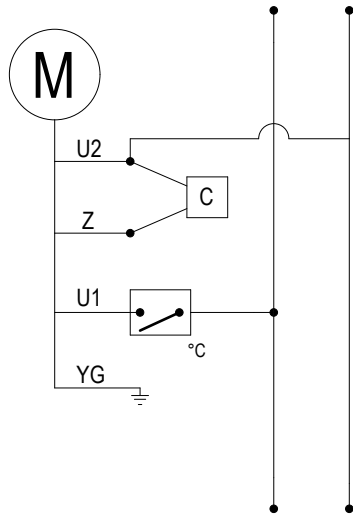

Fig.1

# Collegamenti elettrici

## Electric Wiring



230V AC 1 PHASE

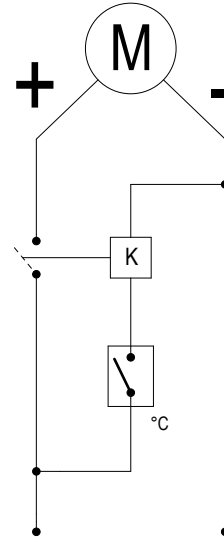

12-24V DC

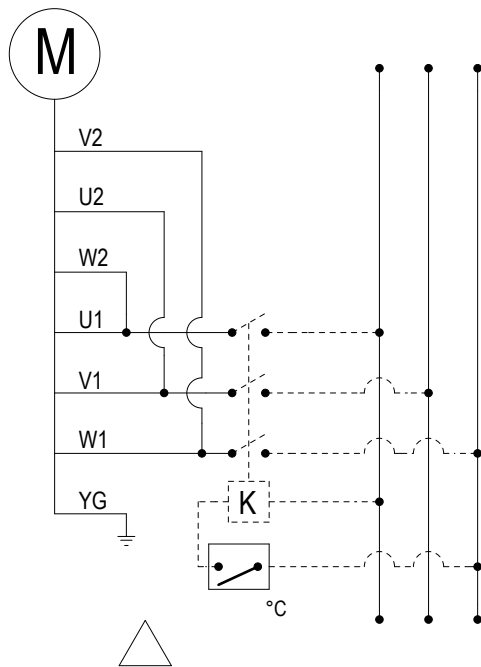

230V AC 3 PHASE

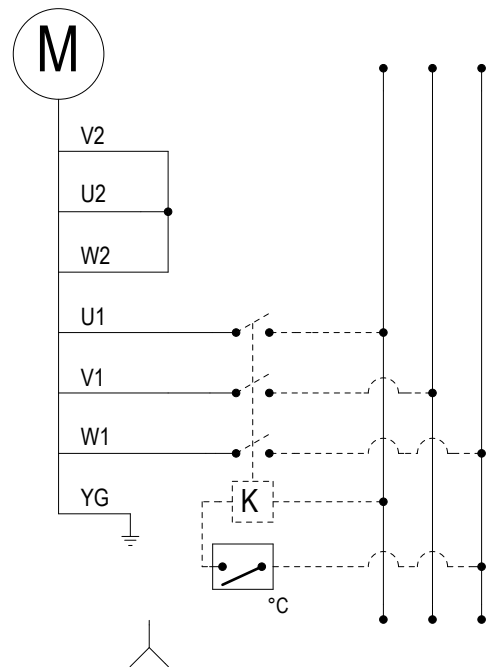

400V AC 3 PHASE

°C = Termostato NA./Thermostat No.  
K = Relè/Relay

# Modulo richiesta dati

## Sheet for cooler selection



CLIENTE <i>COMPANY</i>	
RICHIEDENTE <i>NAME</i>	

### ARIA-OLIO *AIR-OIL*

PORTATA OLIO <i>OIL FLOW RATE</i>	Imp	
POTENZA INSTALLATA <i>TOTAL POWER</i>	KW	
POTENZA DA DISSIPARE <i>POWER TO BE DISSIPATED</i>	KW	
TEMPERATURA INGRESSO OLIO <i>OIL TEMPERATURE INLET</i>	°C	
TEMPERATURA ARIA MAX <i>MAX AMBIENT TEMPERATURE</i>	°C	
VISCOSITÀ OLIO <i>OIL VISCOSITY</i>	cst	
PRESSIONE DI LAVORO <i>WORKING PRESSURE</i>	bar	

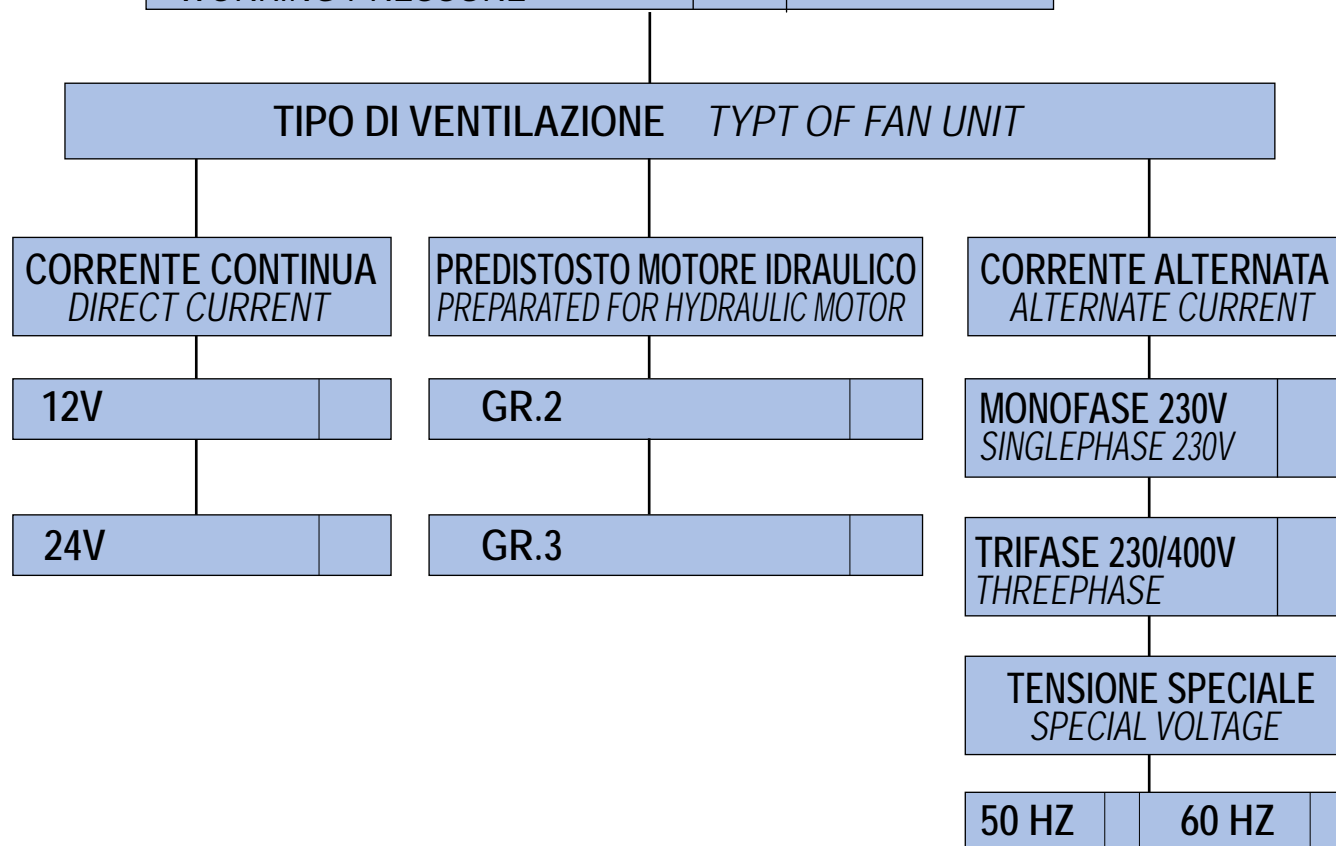

**2**

**V24**

**03**

**2**

**01**

### TIPO DI SISTEMA *COOLER SERIES*

V24 (HPV 24)

### TIPO DI MOTORIZZAZIONE *FAN MOTOR TYPE*

- 01 AC 230V 50 Hz
- 03 AC 230V-400V 50Hz
- 04 AC 230V-400V 50-60 Hz (B14)
- 12 DC 12V
- 24 DC 24V
- 56 Pred. per mot. idr. gr. 2 Prep. for hydr. mot. gr. 2

### TERMOSTATI *THERMOSTATS*

- |   |                                 |  |              |
|---|---------------------------------|--|--------------|
| 1 | Termostato fisso                | <i>Fixed thermostat</i>                | 40-28°       |
| 2 | Termostato fisso                | <i>Fixed thermostat</i>                | 50-38°       |
| 3 | Termostato fisso                | <i>Fixed thermostat</i>                | 60-48°       |
| 4 | Termostato fisso                | <i>Fixed thermostat</i>                | 70-58°       |
| 5 | Termostato fisso                | <i>Fixed thermostat</i>                | 80-68°       |
| 6 | Termostato fisso                | <i>Fixed thermostat</i>                | 90-78°       |
| 8 | Termostato regolabile           | <i>Adjustable thermostat</i>           | 0-90° (TC2)  |
| 9 | Termostato regolabile collegato | <i>Connected adjustable thermostat</i> | 0-120° (TC2) |

### TIPO DI VENTILAZIONE *VENTILATING TYPE*

- 01 Aspirante *Suction air flow*
- 02 Soffiante *Blowing air flow*

# Dati tecnici valvola by-pass Technical data by-pass valve - (1.5 bar)



Detail

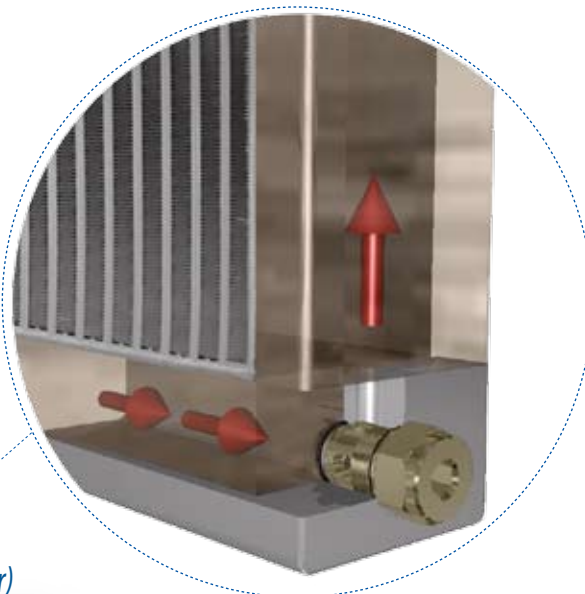

Valvola cartuccia tipo 2 / Cartridge valve type 2 - (1.5 bar)

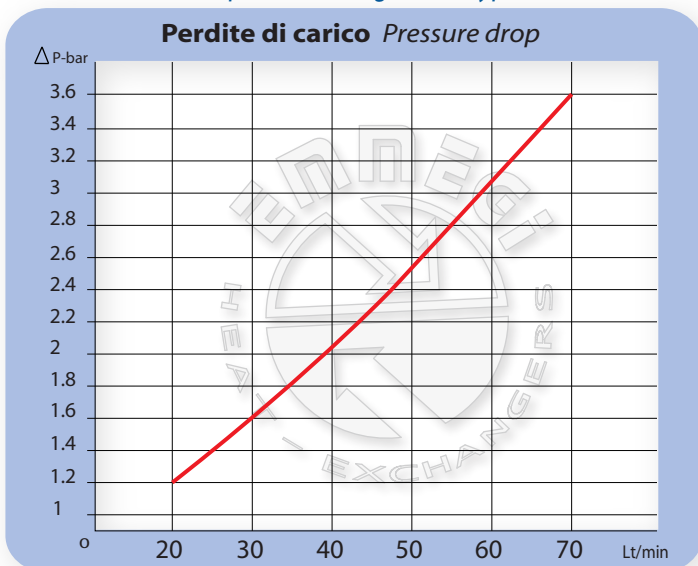

Gli scambiatori aria -olio serie HPV- nascono dalle esigenze applicative ad ampio raggio espresse dal mercato.

Punto di forza di questi prodotti é rappresentato dal by-pass integrato che ne amplifica la semplicità d' uso, eliminando la necessità di dovere aggiungere da parte del cliente una valvola autonoma, assicurando così elevata funzionalità.

*The air-oil heat-exchangers HPV Series were born to answer the large application needs of the market. The main characteristic of this new products is the integrated by-pass valve that will simplify their employ and will avoid the customers to add an external and independent valve. This will guarantee a very high efficiency.*

Valvola cartuccia tipo 3 / Cartridge valve type 3 - (1.5 bar)

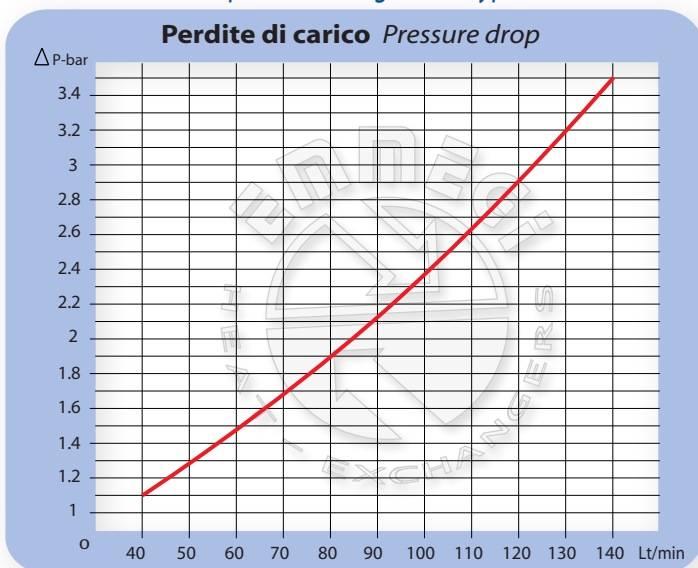

Schema idraulico  
Hydraulic circuit

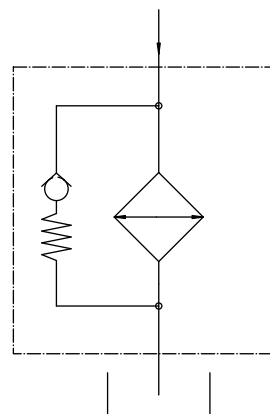



# Dimensioni Dimensions

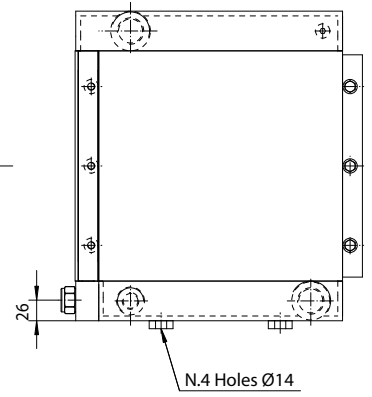
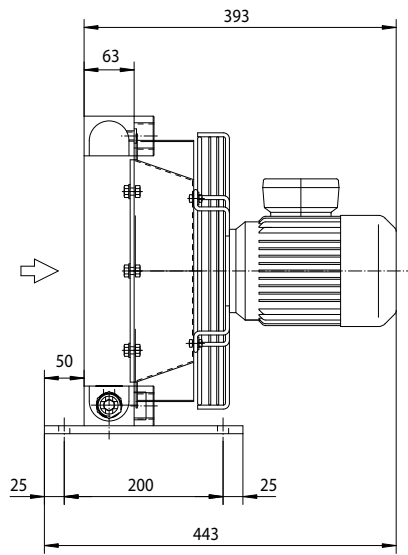
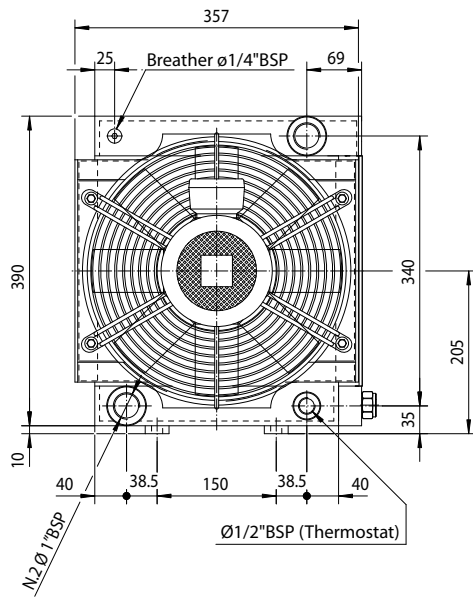

P/N 2V1203###

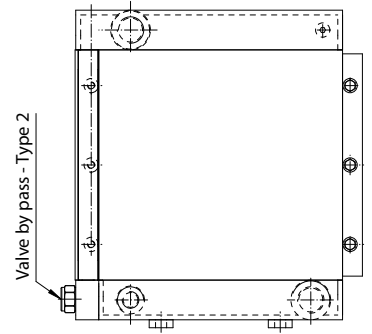
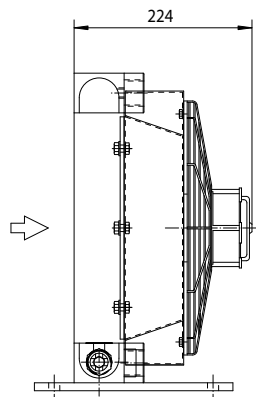
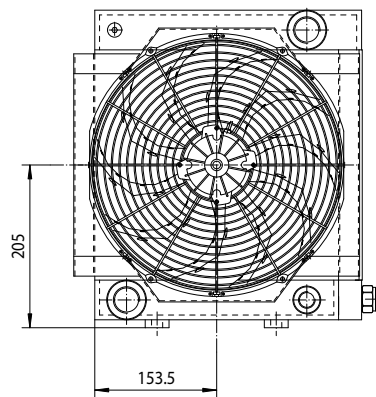

P/N 2V1212###  
P/N 2V1224###

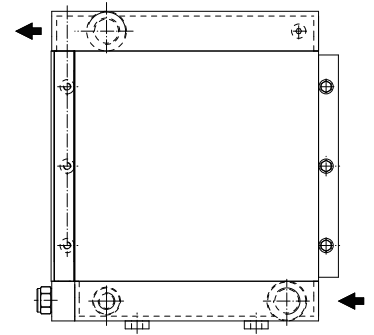
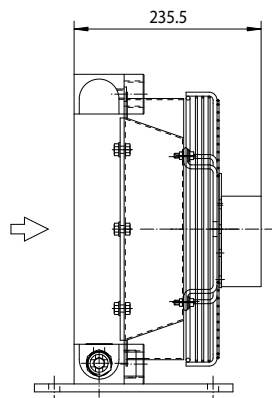
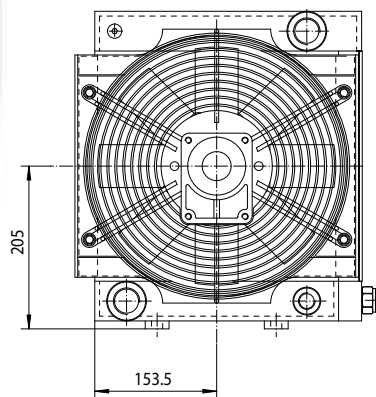

P/N 2V1256###

Le dimensioni di ingombro e le caratteristiche tecniche non sono impegnative  
Over-all dimensions and technical characteristic are not binding

# Dati tecnici Technical Data



HPV 12

P/N	V	Hz	kW	A	rpm	ø Fan	dB(A)	(m³/h)	IP	lt	Kg
2V1203###	230-400 B14 AC	50/60	0,250	0,7	1450	315	72	1670	55	1,9	17
2V1212###	12 DC	/	0,160	11,3	3000	305	77	1590	68		15
2V1224###	24 DC	/	0,160	6,3	3000	305	80	1700	68		15
2V1256###	Prepared for Gr.2 hydraulic monitor					315			/		16

Contattare EMMEGI Contact EMMEGI

## Diagramma rendimento Performance diagram

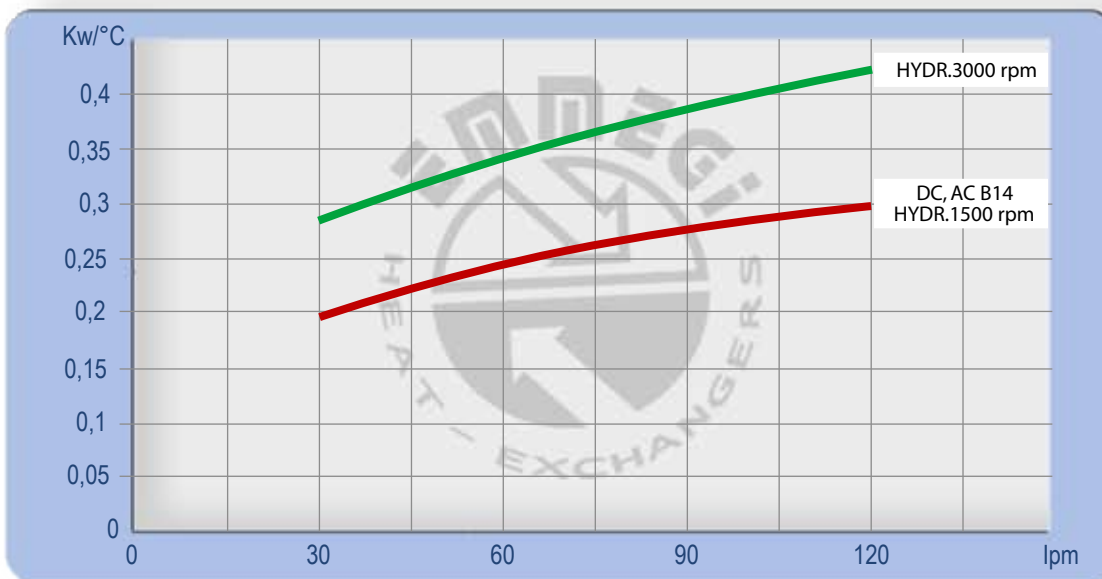

## Perdite di carico Pressure drop (ISO VG 32)

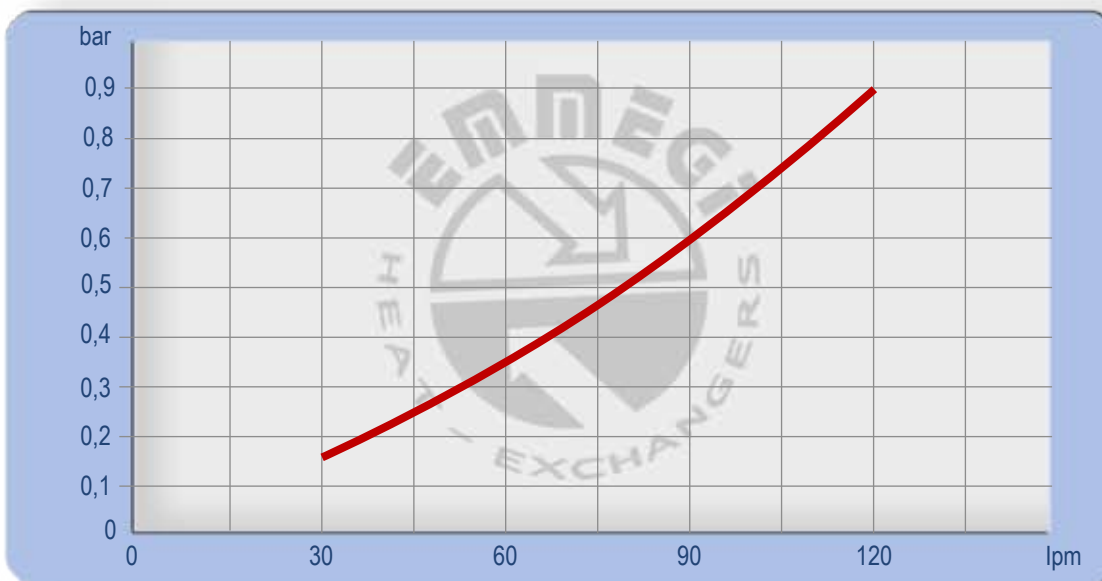

Fattore di correzione - F -( perdite di carico) Correction factor - F - (Pressure drop)

cst	10	15	20	30	40	50	60	80	100	200	300
F	0,5	0,65	0,77	1	1,2	1,4	1,6	1,9	2,1	3,3	4,3

# Dimensioni Dimensions

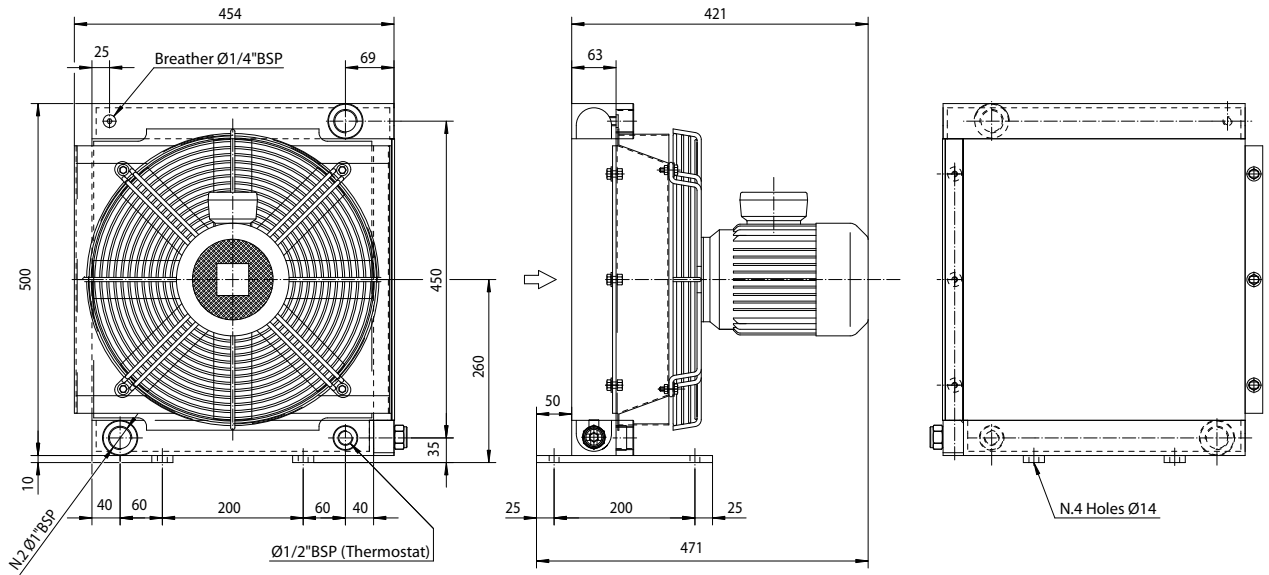

P/N 2V1803###

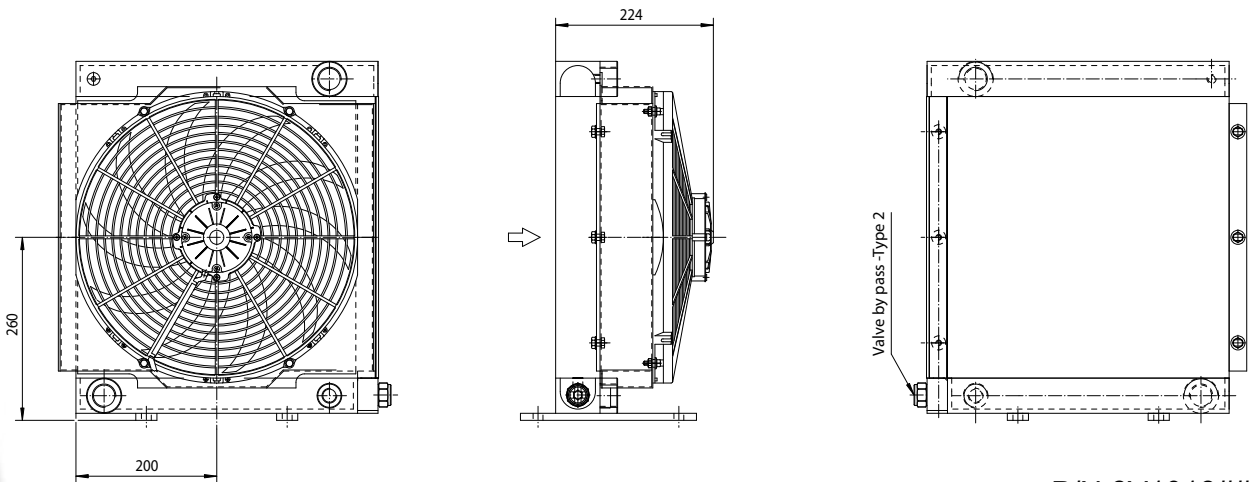

P/N 2V1812###  
P/N 2V1824###

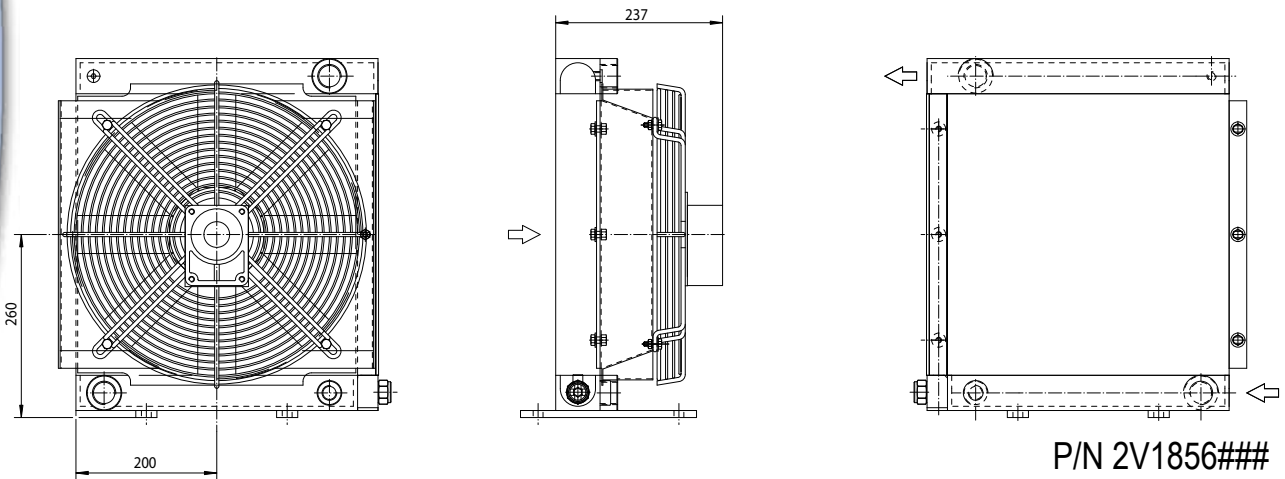

P/N 2V1856###

Le dimensioni di ingombro e le caratteristiche tecniche non sono impegnative  
Over-all dimensions and technical characteristic are not binding

# Dati tecnici Technical Data



HPV 18

P/N	V	Hz	kW	A	rpm	ø Fan	dB(A)	(m³/h)	IP	lt	Kg
2V1803###	230-400 B14 AC	50/60	0,370	0,95	1450	400	77	3350	55	2,9	20
2V1812###	12 DC	/	0,210	13,3	2500	385	77	2950	68		18
2V1824###	24 DC	/	0,210	9,3	2500	385	81	3100	68		18
2V1856###	Prepared for Gr.2 hydraulic monitor					400			/		19

Contattare EMMEGI Contact EMMEGI

## Diagramma rendimento Performance diagram

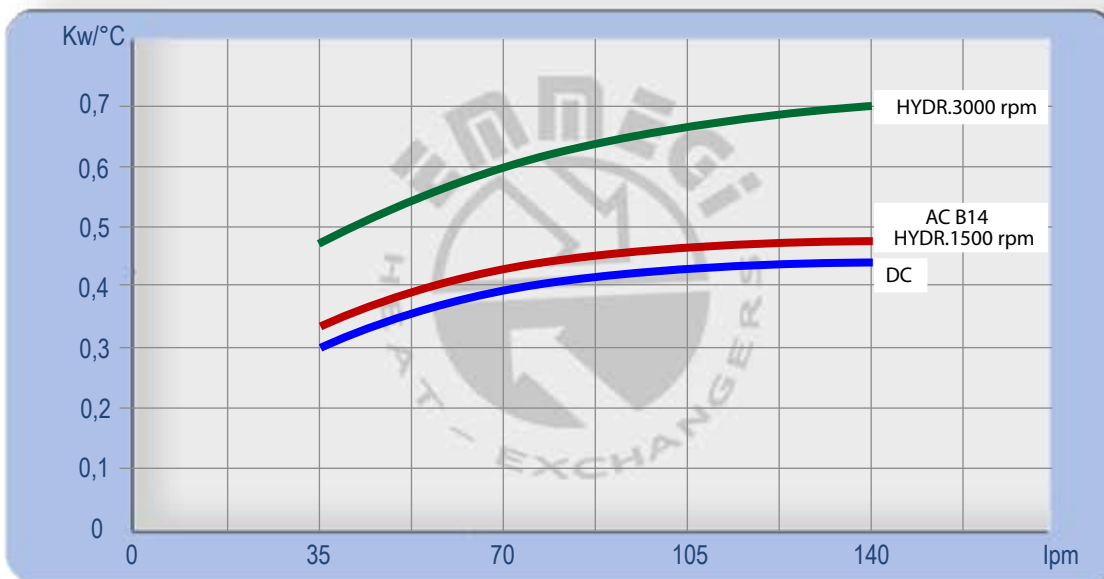

## Perdite di carico Pressure drop (ISO VG 32)

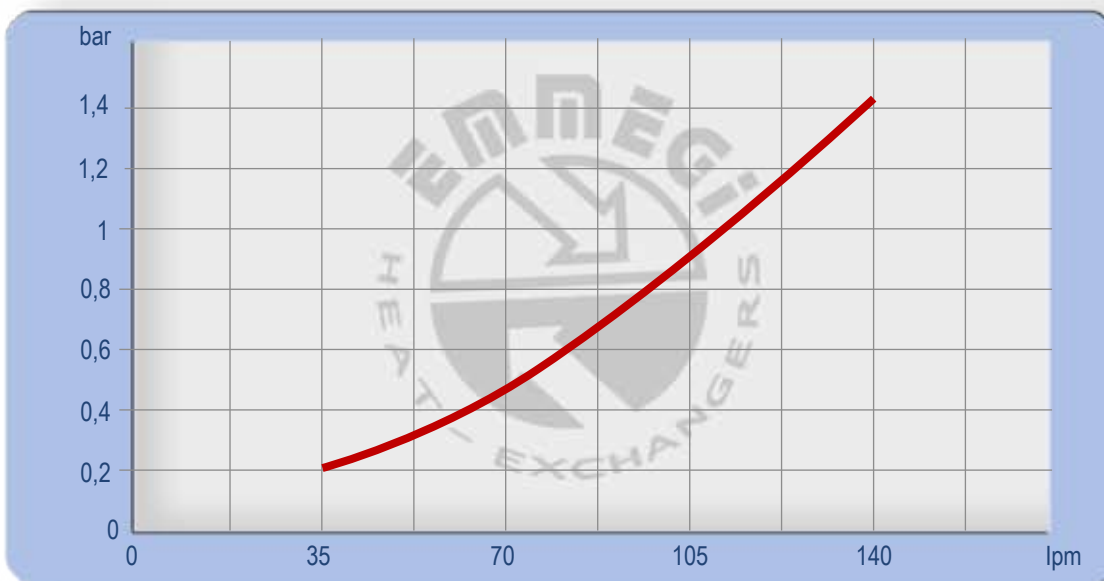

Fattore di correzione - F -( perdite di carico) Correction factor - F - (Pressure drop)

cst	10	15	20	30	40	50	60	80	100	200	300
F	0,5	0,65	0,77	1	1,2	1,4	1,6	1,9	2,1	3,3	4,3

# Dimensioni Dimensions

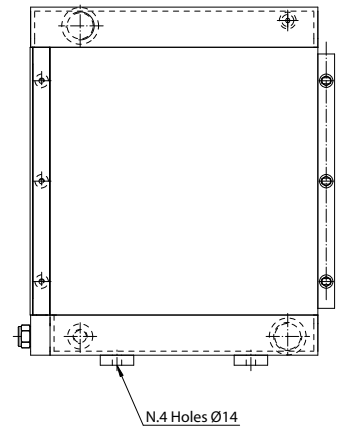
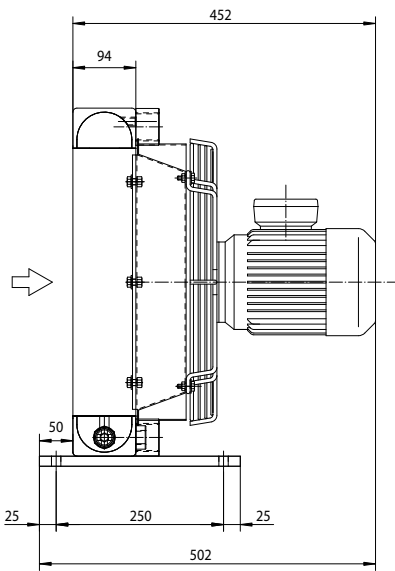
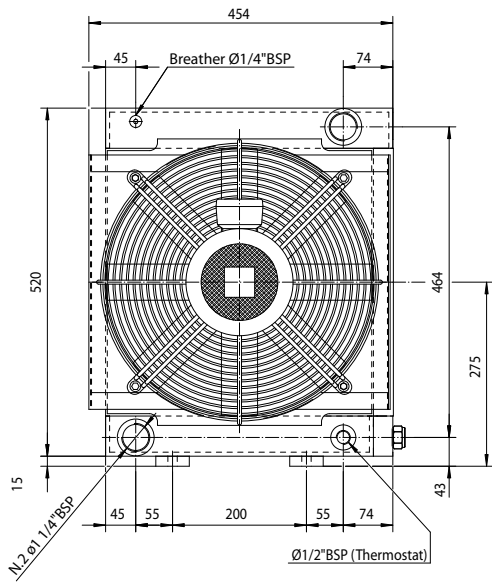

P/N 2V2403###

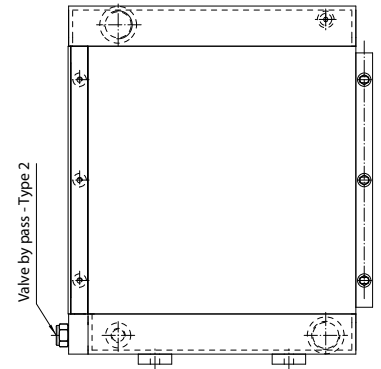
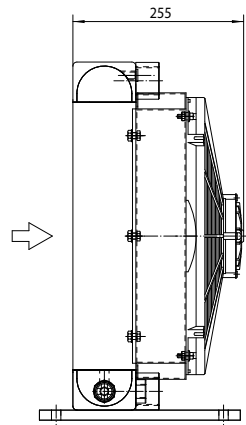
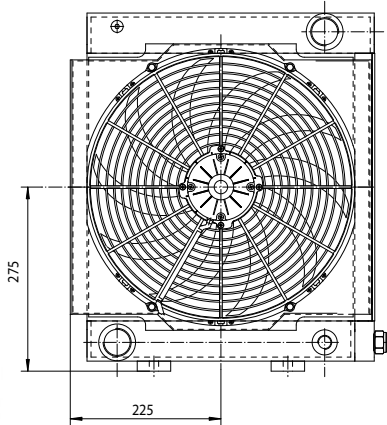

P/N 2V2412###  
P/N 2V2424###

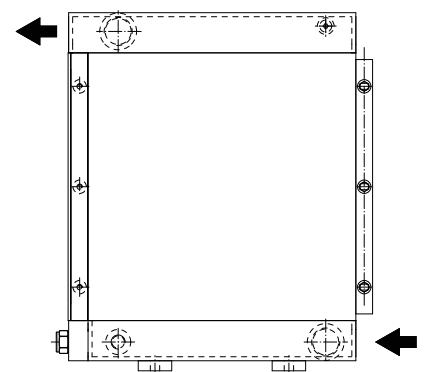
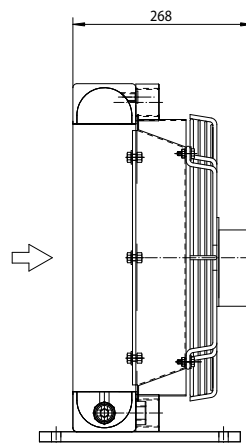
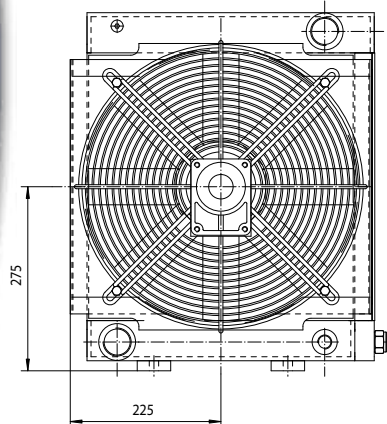

P/N 2V2456###

Le dimensioni di ingombro e le caratteristiche tecniche non sono impegnative  
Over-all dimensions and technical characteristic are not binding

# Dati tecnici Technical Data



HPV 24

P/N	V	Hz	kW	A	rpm	ø Fan	dB(A)	(m³/h)	IP	lt	Kg
2V2403###	230-400 B14 AC	50/60	0,550	1,35	1450	400	79	2800	55	2,9	28
2V2412###	12 DC	/	0,210	13,2	2500	385	77	2100	68		22
2V2424###	24 DC	/	0,210	8,4	2500	385	80	2250	68		22
2V2456###	Prepared for Gr.2 hydraulic monitor					400			/		23

Contattare EMMEGI Contact EMMEGI

## Diagramma rendimento Performance diagram

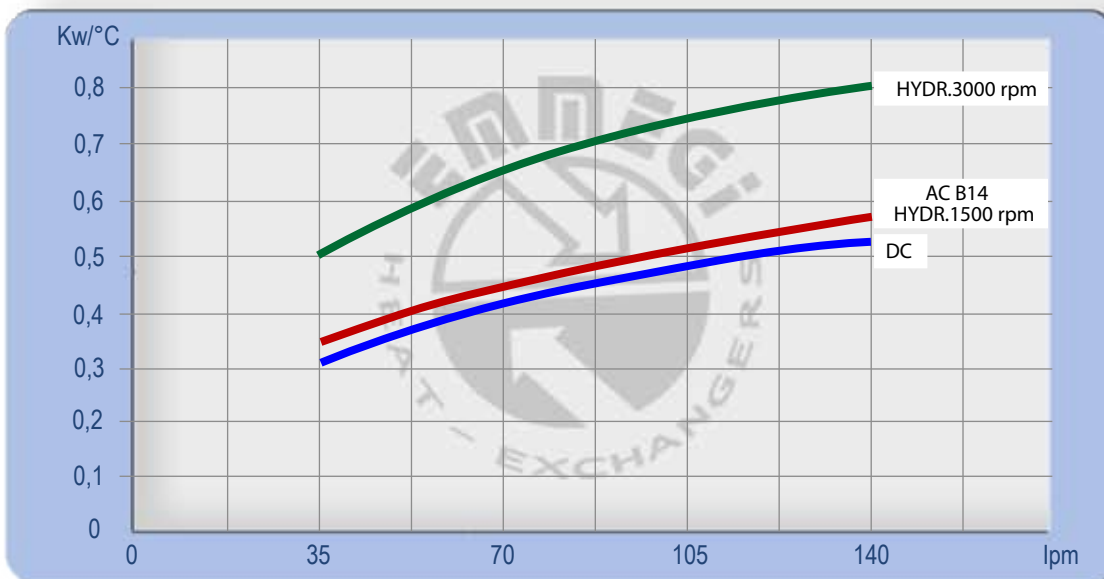

## Perdite di carico Pressure drop (ISO VG 32)

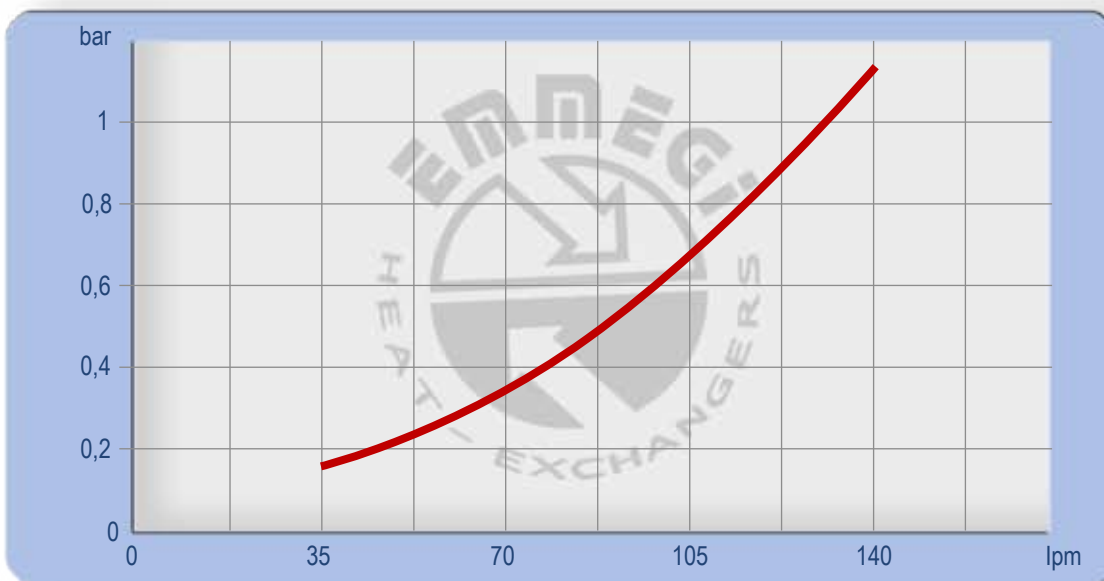

Fattore di correzione - F -( perdite di carico) Correction factor - F - (Pressure drop)

cst	10	15	20	30	40	50	60	80	100	200	300
F	0,5	0,65	0,77	1	1,2	1,4	1,6	1,9	2,1	3,3	4,3

# Dimensioni Dimensions

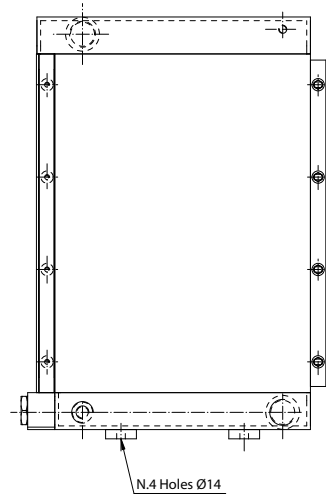
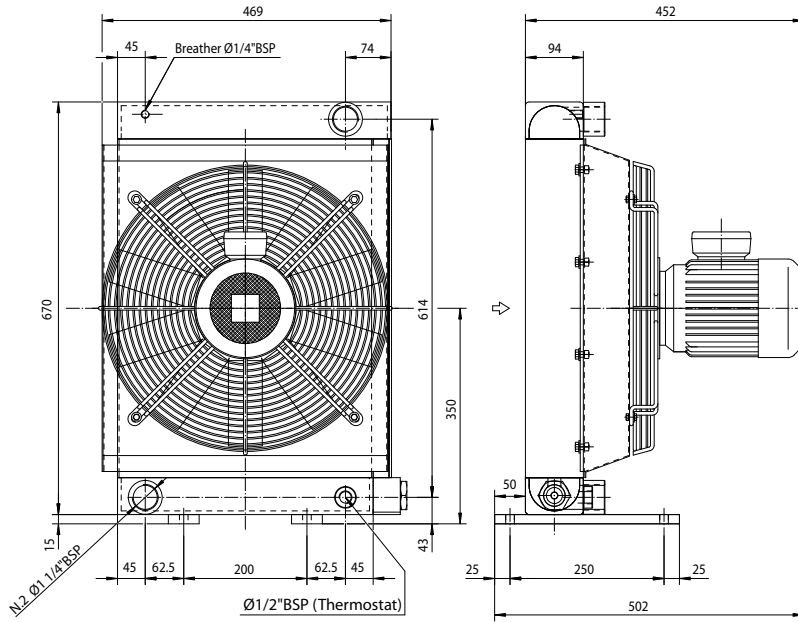

P/N 2V3003###

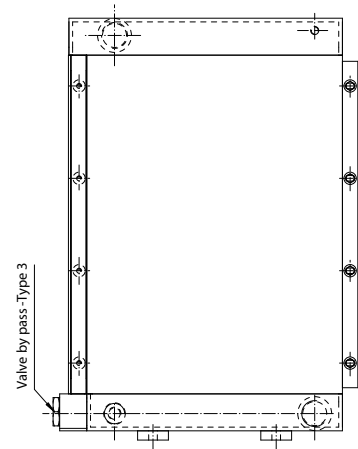
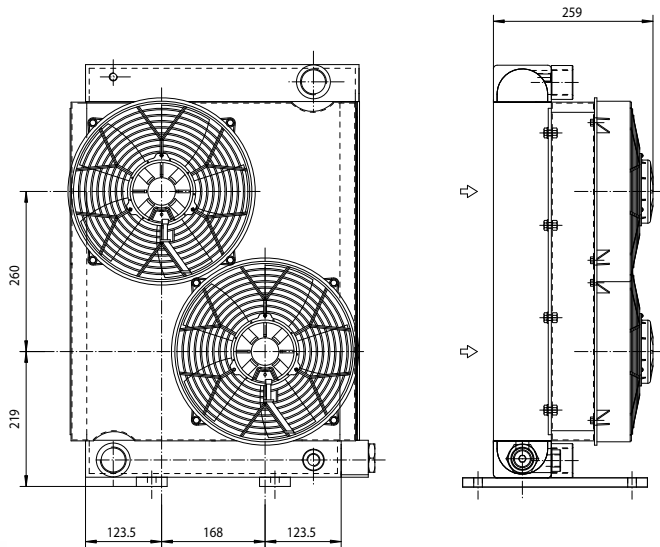

P/N 2V3012###  
P/N 2V3024###

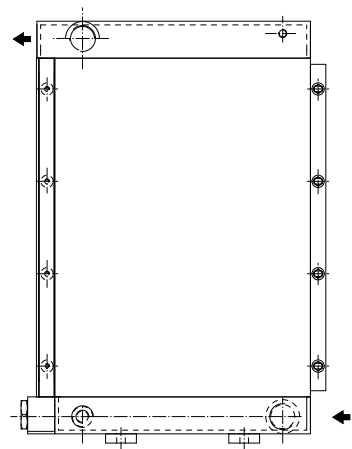
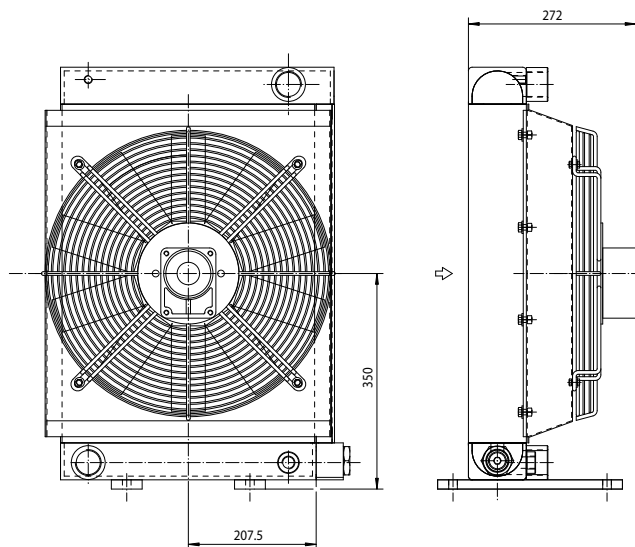

P/N 2V3056###

Le dimensioni di ingombro e le caratteristiche tecniche non sono impegnative  
Over-all dimensions and technical characteristic are not binding

HPV 30

# Dati tecnici Technical Data



HPV 30

P/N	V	Hz	kW	A	rpm	ø Fan	dB(A)	(m³/h)	IP	lt	Kg
2V3003 ###	230-400 B14 AC	50/60	0,750	1,8	1450	450	82	4000	55	6,8	37
2V3012 ###	12 DC	/	0,150	9,5	3100	280	74	1550	68		32
2V3024 ###	24 DC	/	0,150	5,6	3100	280	78	1700	68		32
2V3056 ###	Prepared for Gr.2 hydraulic monitor					450			/		35

 Contattare EMMEGI Contact EMMEGI

## Diagramma rendimento Performance diagram

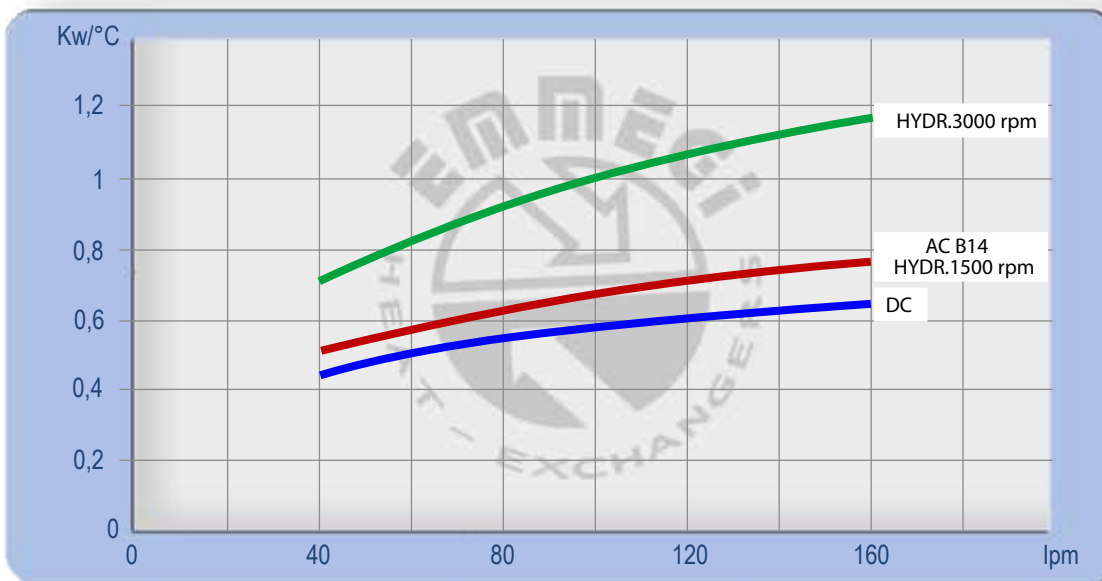

## Perdite di carico Pressure drop (ISO VG 32)

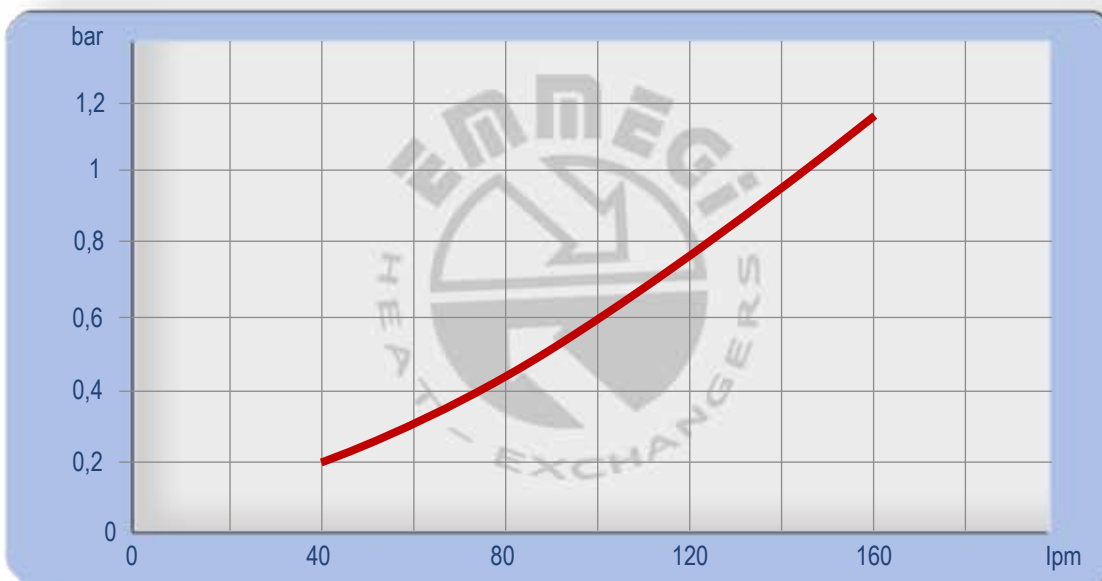

Fattore di correzione - F -( perdite di carico) Correction factor - F - (Pressure drop)

cst	10	15	20	30	40	50	60	80	100	200	300
F	0,5	0,65	0,77	1	1,2	1,4	1,6	1,9	2,1	3,3	4,3



# Dimensioni Dimensions

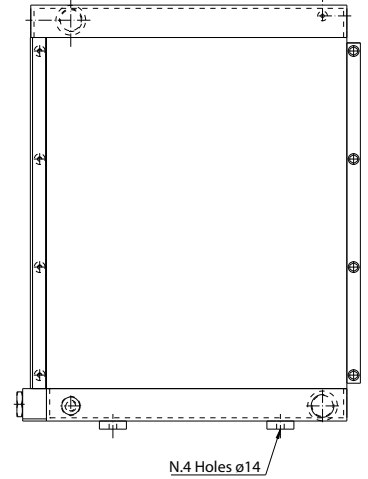
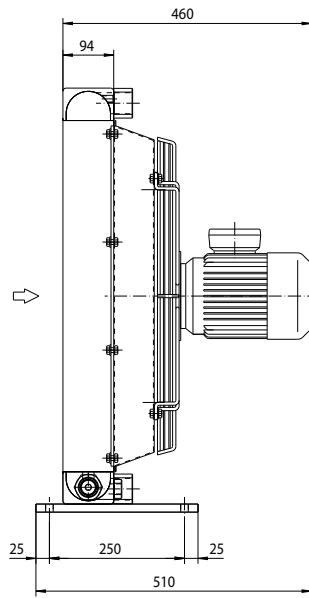
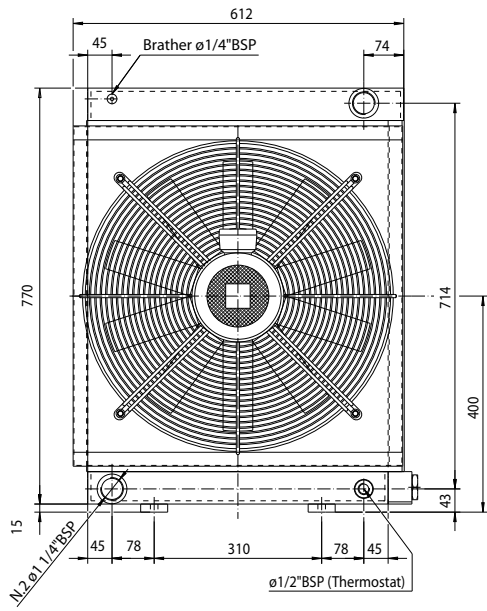

P/N 2V3603###

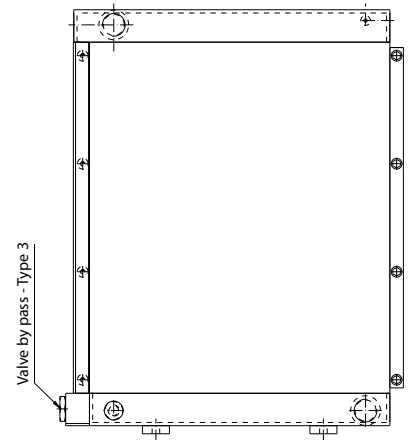
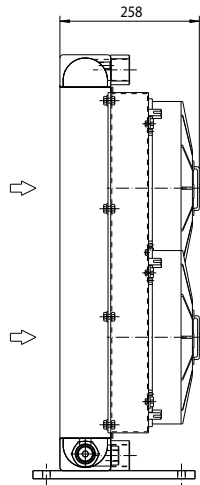
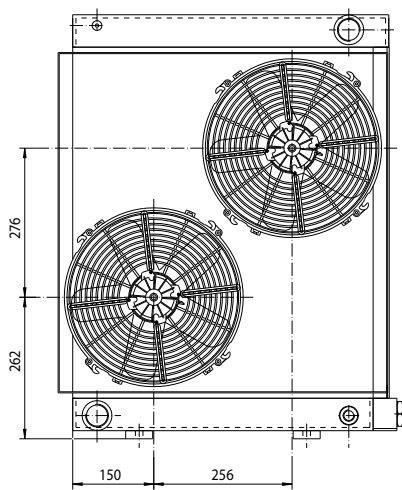

P/N 2V3612###  
P/N 2V3624###

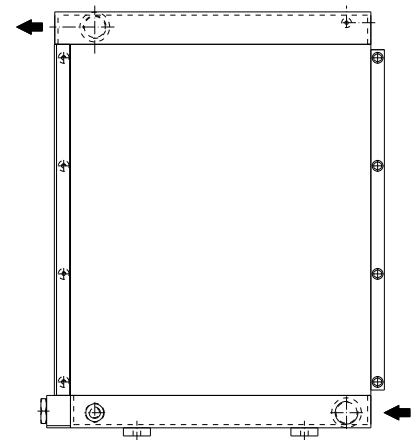
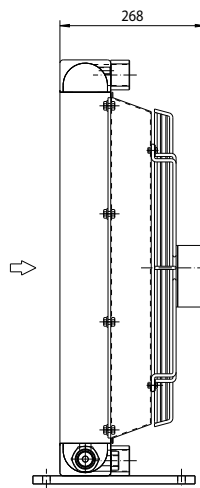
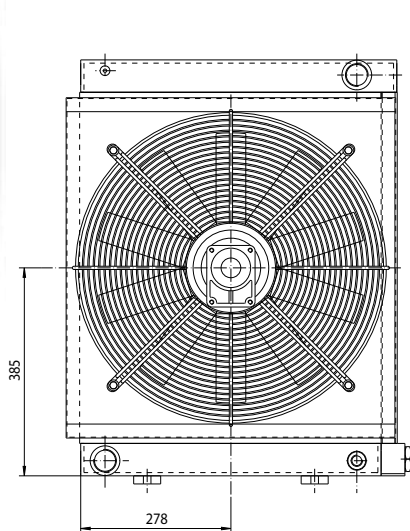

P/N 2V3656###

Le dimensioni di ingombro e le caratteristiche tecniche non sono impegnative  
Over-all dimensions and technical characteristic are not binding

# Dati tecnici Technical Data



HPV 36  
HI

P/N	V	Hz	kW	A	rpm	ø Fan	dB(A)	(m³/h)	IP	lt	Kg
2V3603 ###	230-400 B14 AC	50/60	1,1	2,32	1450	500	82	5650	55	9,4	60
2V3612 ###	12 DC	/	0,200	12,5	3100	305	82	2100	68		50
2V3624 ###	24 DC	/	0,200	7,8	3100	305	84	2400	68		50
2V3656 ###	Prepared for Gr.2 hydraulic monitor					500			/		52

Contattare EMMEGI Contact EMMEGI

## Diagramma rendimento Performance diagram

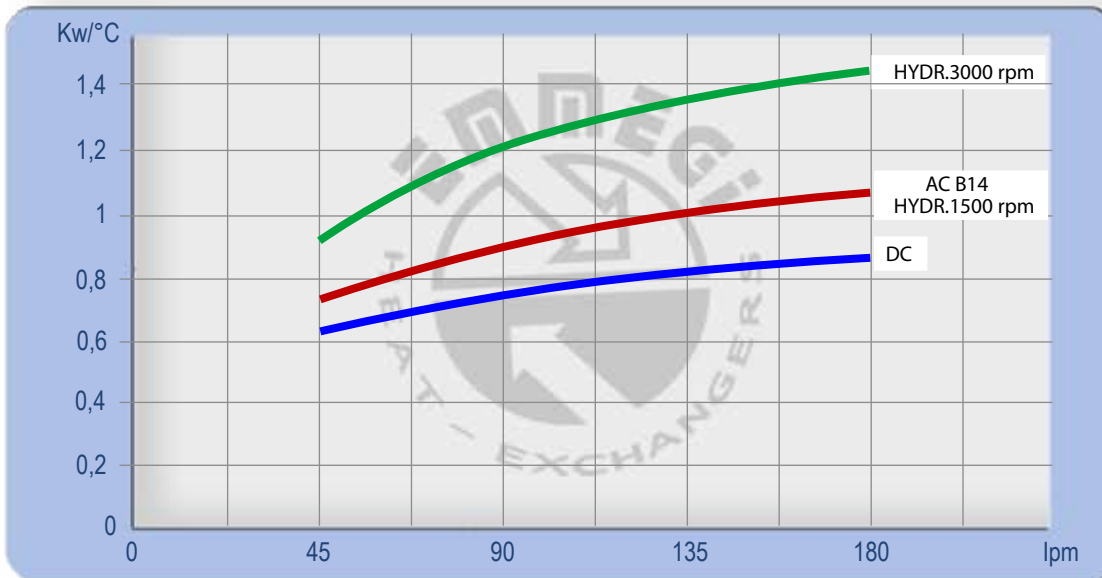

## Perdite di carico Pressure drop ( 32 CTS)

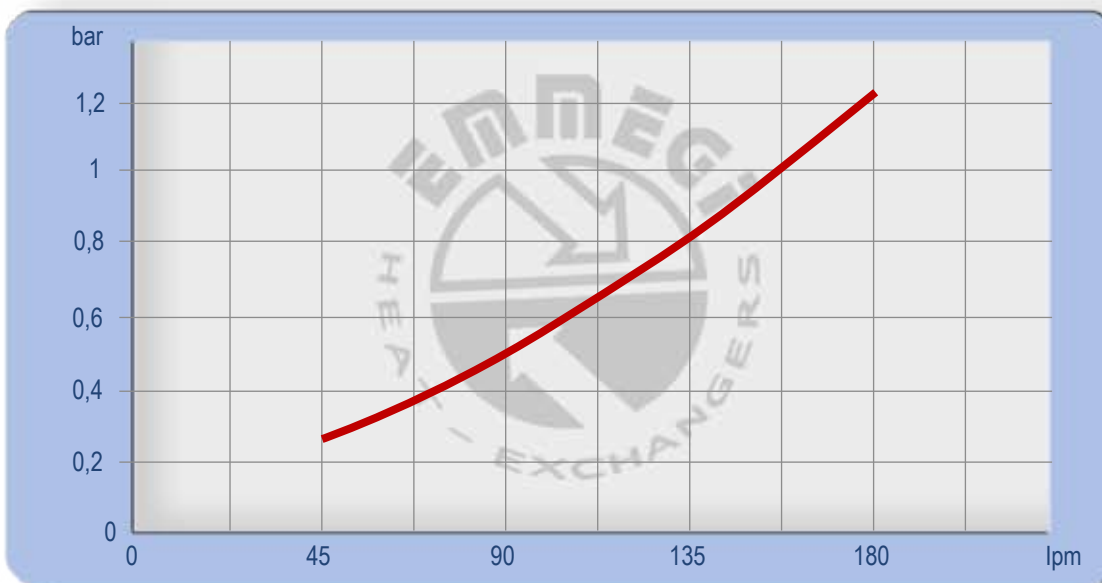

Fattore di correzione - F -( perdite di carico) Correction factor - F - (Pressure drop)

cst	10	15	20	30	40	50	60	80	100	200	300
F	0,5	0,65	0,77	1	1,2	1,4	1,6	1,9	2,1	3,3	4,3

# Dimensioni Dimensions

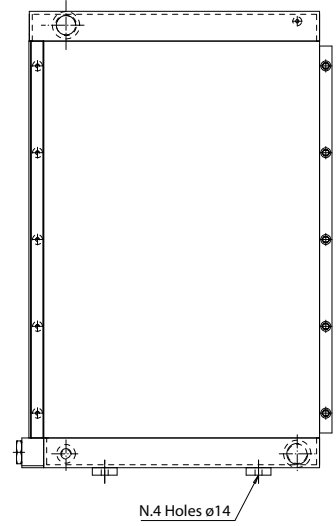
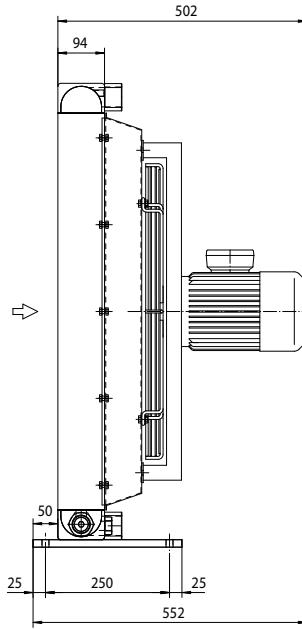
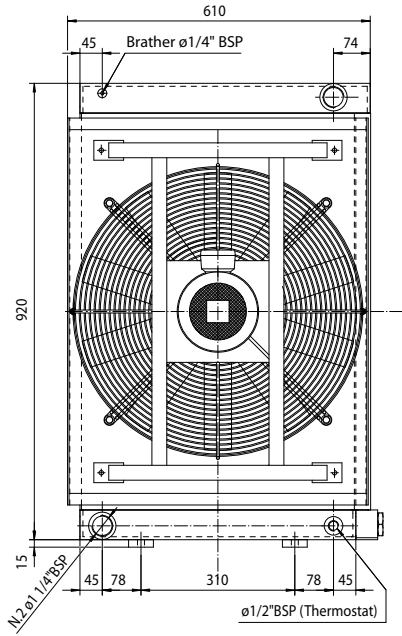

P/N 2V4203###

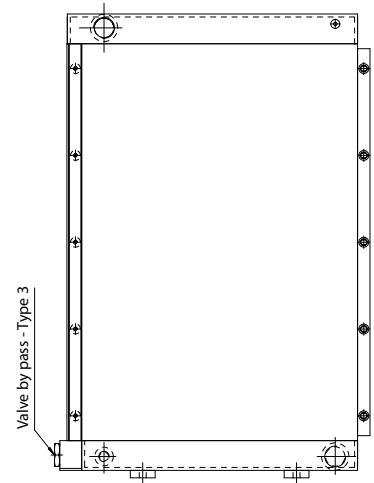
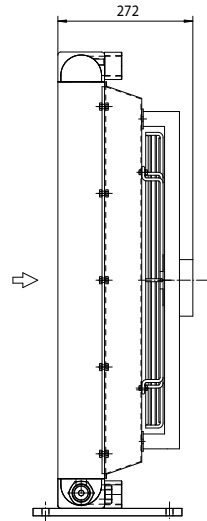
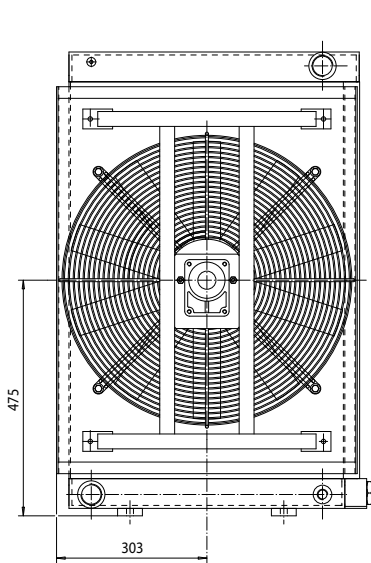

P/N 2V4256###

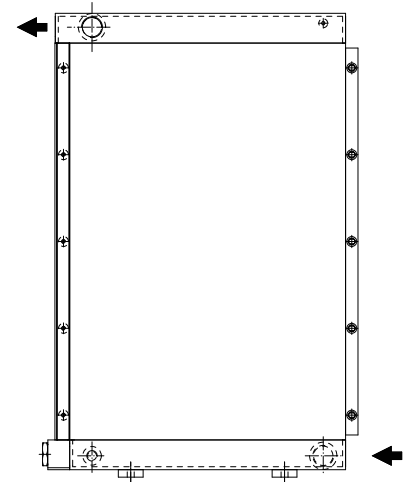
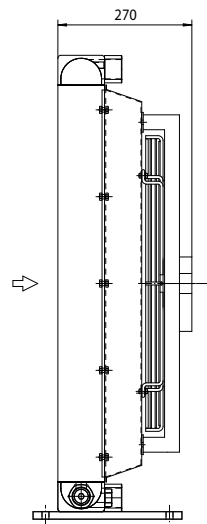
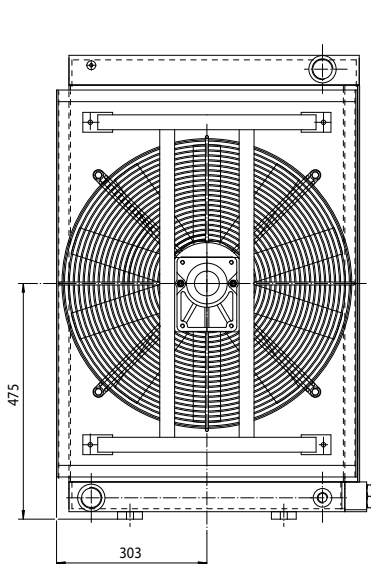

P/N 2V4258###

Le dimensioni di ingombro e le caratteristiche tecniche non sono impegnative  
Over-all dimensions and technical characteristic are not binding

# Dati tecnici Technical Data



HPV 42  
A1H1

P/N	V	Hz	kW	A	rpm	ø Fan	dB(A)	(m³/h)	IP	lt	Kg
2V4203 ###	230-400 B14 AC	50/60	1,1	2,5	1450	560	84	7550	55		65
2V4256 ###	Prepared for Gr.2 hydraulic monitor					560			/	10,6	58
2V4258 ###	Prepared for Gr.2 hydraulic monitor					560			/		58

Contattare EMMEGI Contact EMMEGI

## Diagramma rendimento Performance diagram

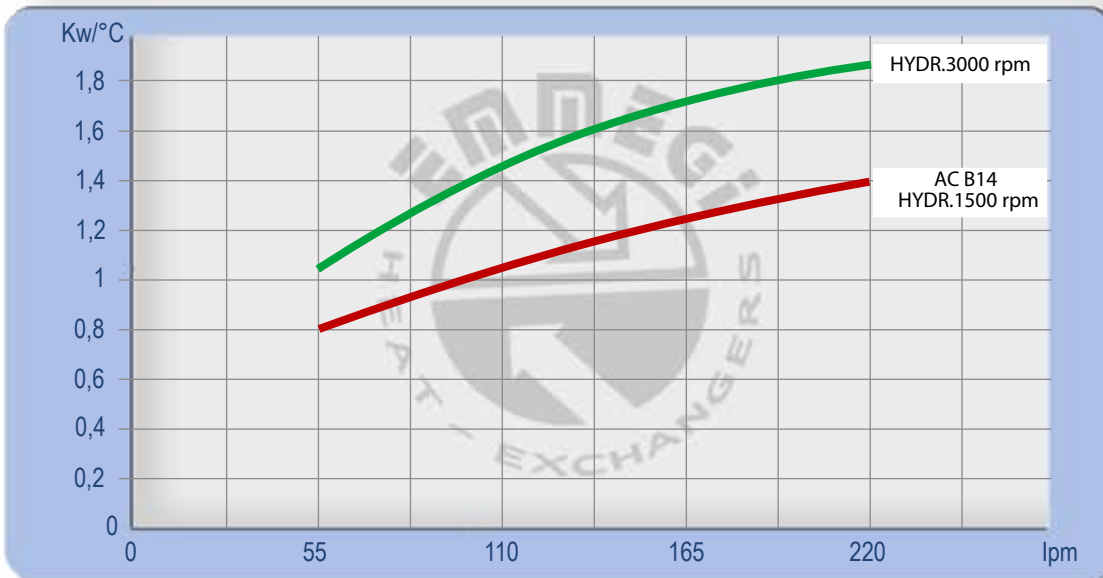

## Perdite di carico Pressure drop ( ISO VG 32)

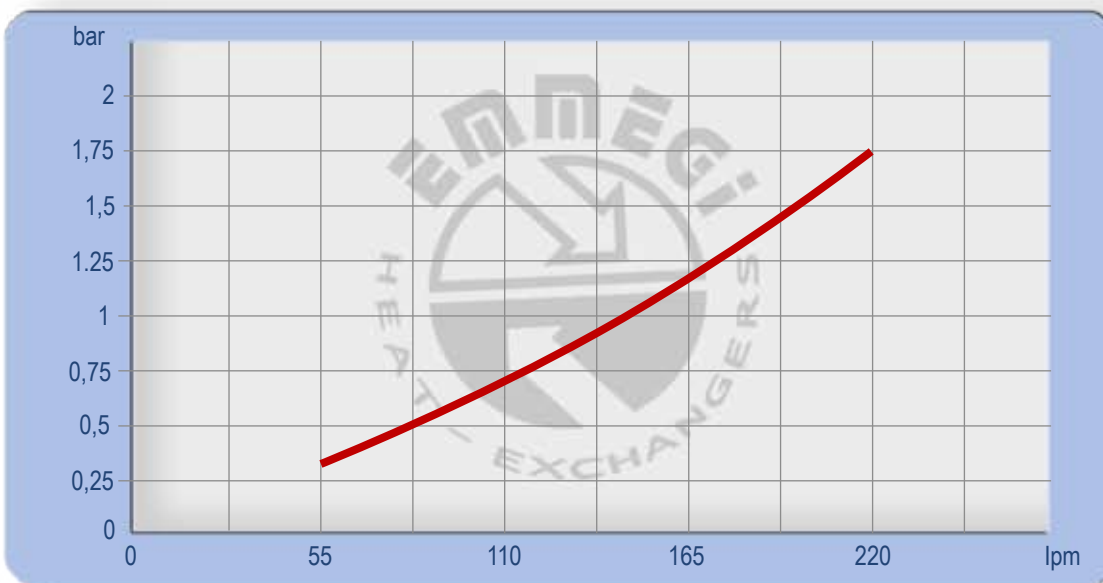

**Fattore di correzione - F - (perdite di carico) Correction factor - F - (Pressure drop)**

cst	10	15	20	30	40	50	60	80	100	200	300
F	0,5	0,65	0,77	1	1,2	1,4	1,6	1,9	2,1	3,3	4,3

# Dimensioni Dimensions

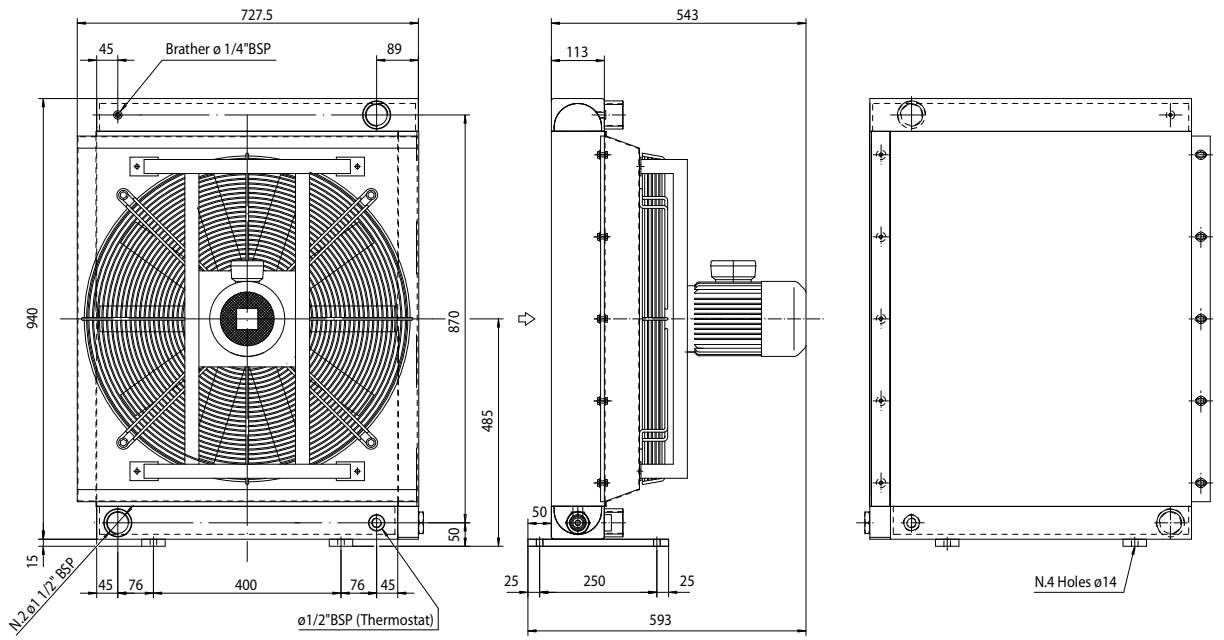

P/N 2V5003###

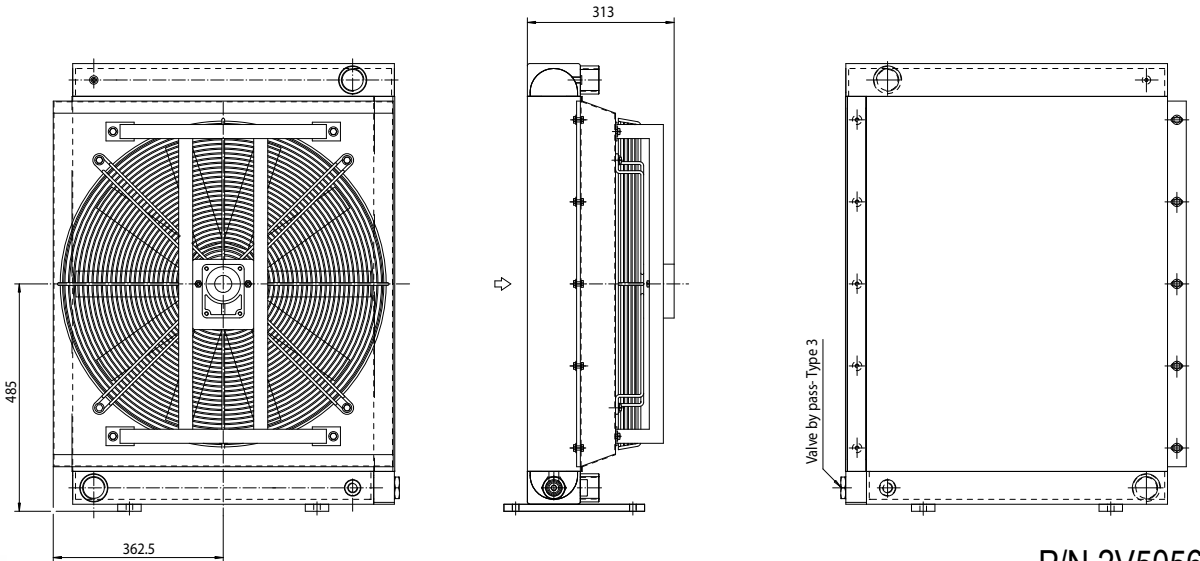

P/N 2V5056###

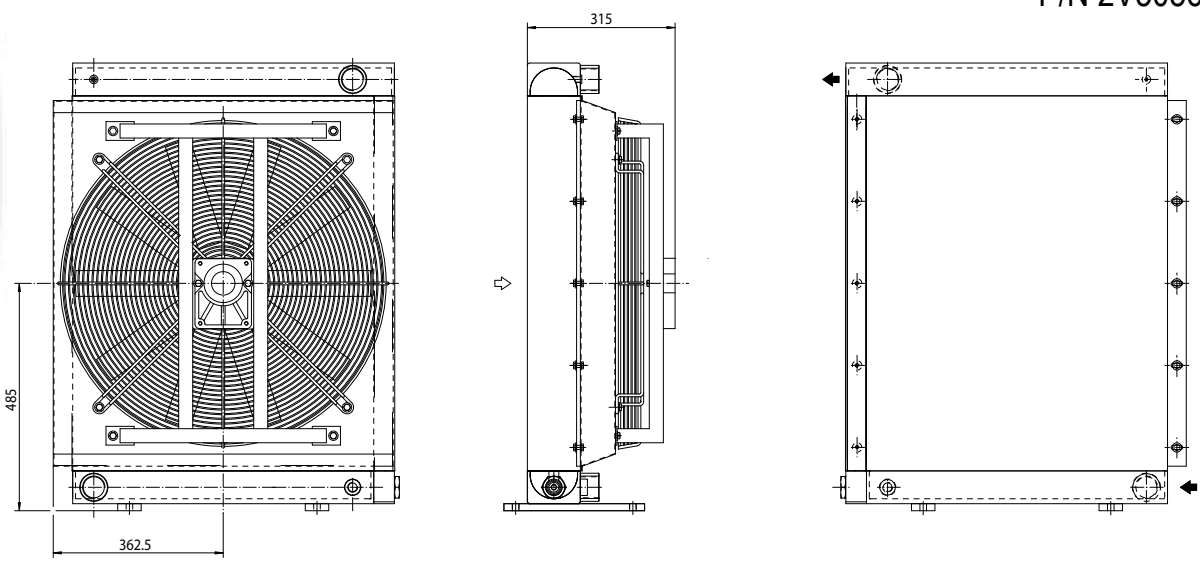

P/N 2V5058###

Le dimensioni di ingombro e le caratteristiche tecniche non sono impegnative  
 Over-all dimensions and technical characteristic are not binding

HPV 50

# Dati tecnici Technical Data



HPV 50  
AC B14

P/N	V	Hz	kW	A	rpm	ø Fan	dB(A)	(m³/h)	IP	lt	Kg
2V5003 ###	230-400 B14 AC	50/60	1,1	2,8	980	630	80	7550	55		90
2V5056 ###	Prepared for Gr.2 hydraulic monitor					630			/	14,2	83
2V5058 ###	Prepared for Gr.2 hydraulic monitor					630			/		83

Contattare EMMEGI Contact EMMEGI

## Diagramma rendimento Performance diagram

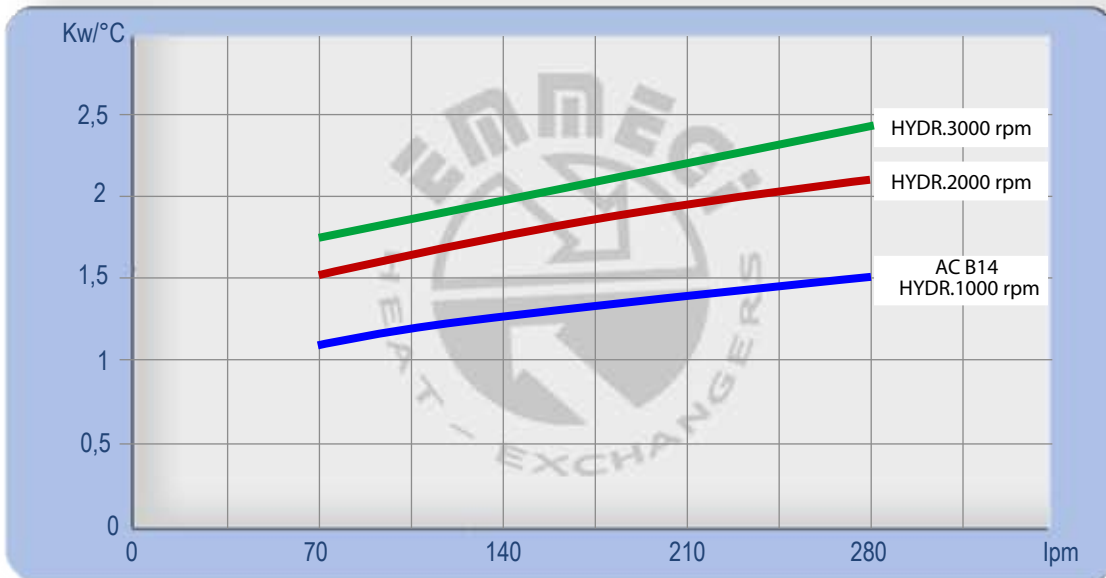

## Perdite di carico Pressure drop (ISO VG 32)

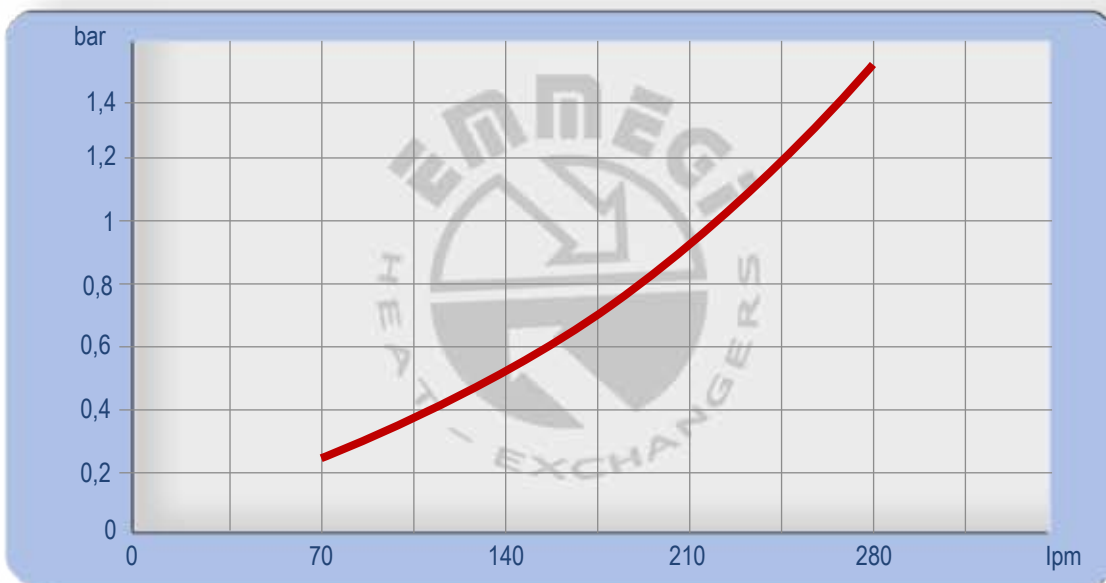

Fattore di correzione - F - (perdite di carico) Correction factor - F - (Pressure drop)

cst	10	15	20	30	40	50	60	80	100	200	300
F	0,5	0,65	0,77	1	1,2	1,4	1,6	1,9	2,1	3,3	4,3

# Dimensioni Dimensions

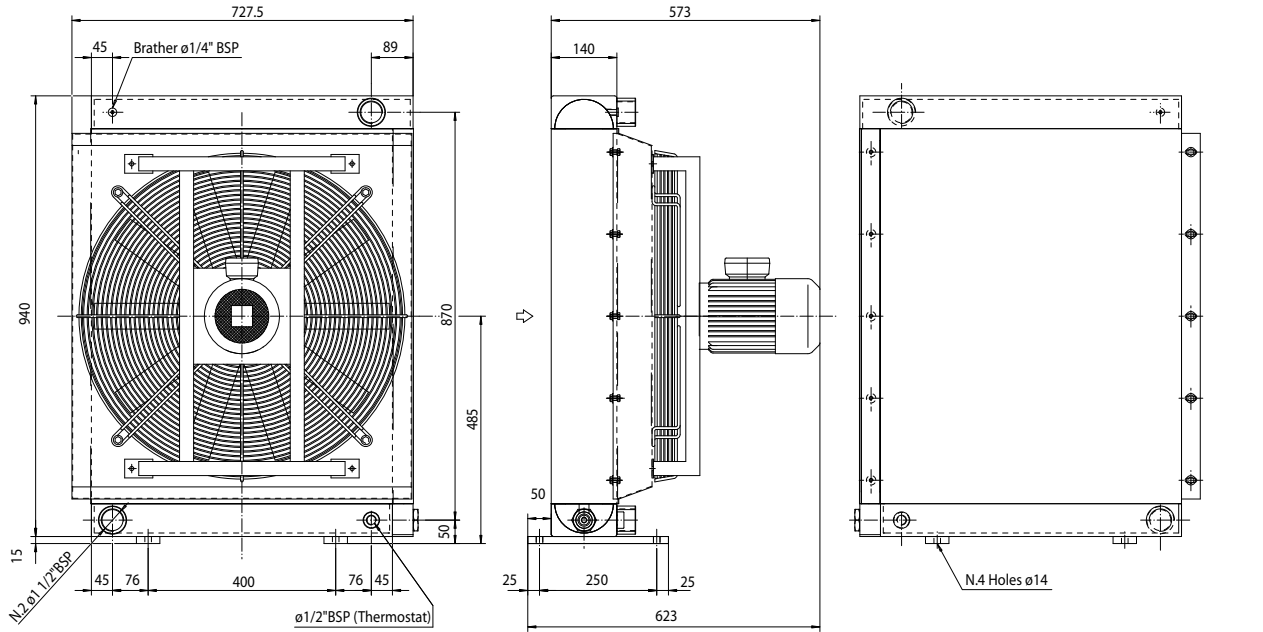

P/N 2V5203###

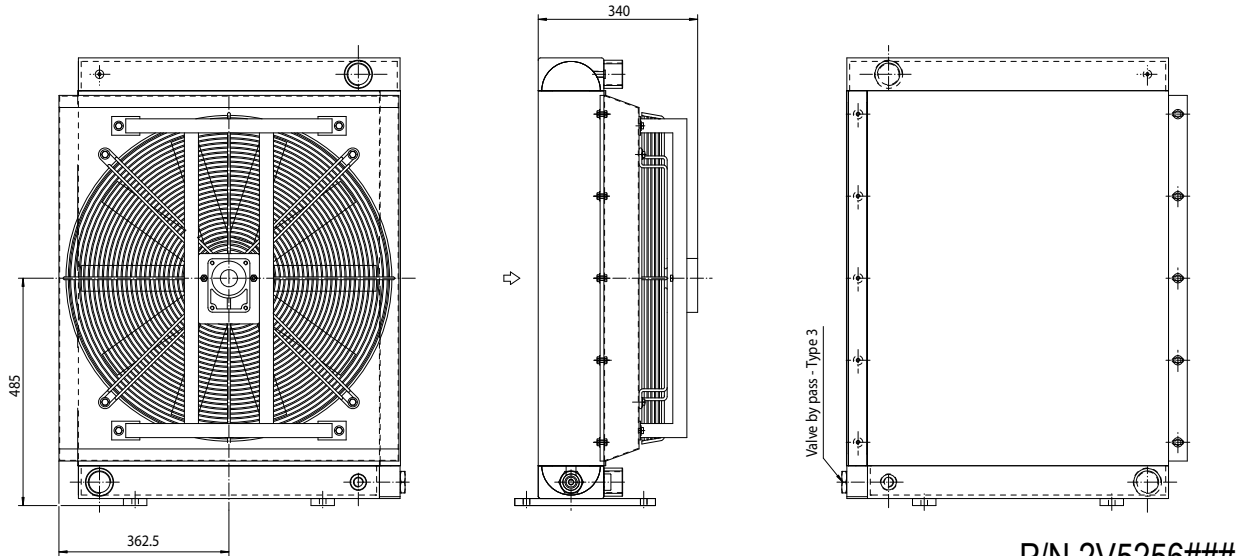

P/N 2V5256###

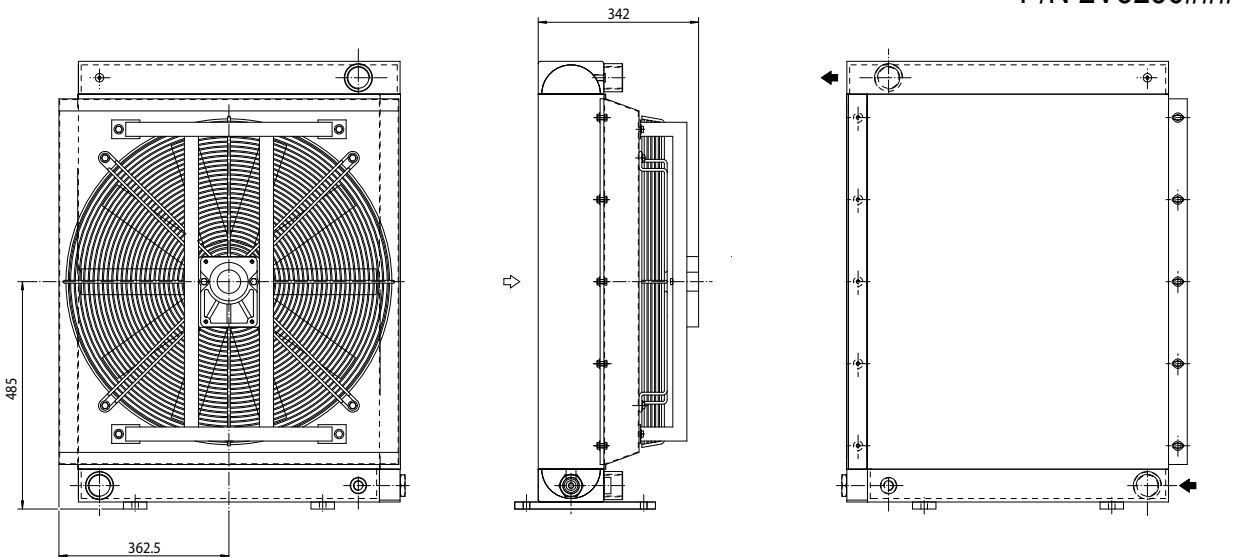

P/N 2V5258###

Le dimensioni di ingombro e le caratteristiche tecniche non sono impegnative  
Over-all dimensions and technical characteristic are not binding

# Dati tecnici Technical Data



HPV 52  
ADH

P/N	V	Hz	kW	A	rpm	ø Fan	dB(A)	(m³/h)	IP	lt	Kg
2V5203 ###	230-400 B14 AC	50/60	1,1	2,82	980	630	80	7050	55		95
2V5256 ###	Prepared for Gr.2 hydraulic monitor					630			/	17,7	89
2V5258 ###	Prepared for Gr.2 hydraulic monitor					630			/		89

Contattare EMMEGI Contact EMMEGI

## Diagramma rendimento Performance diagram

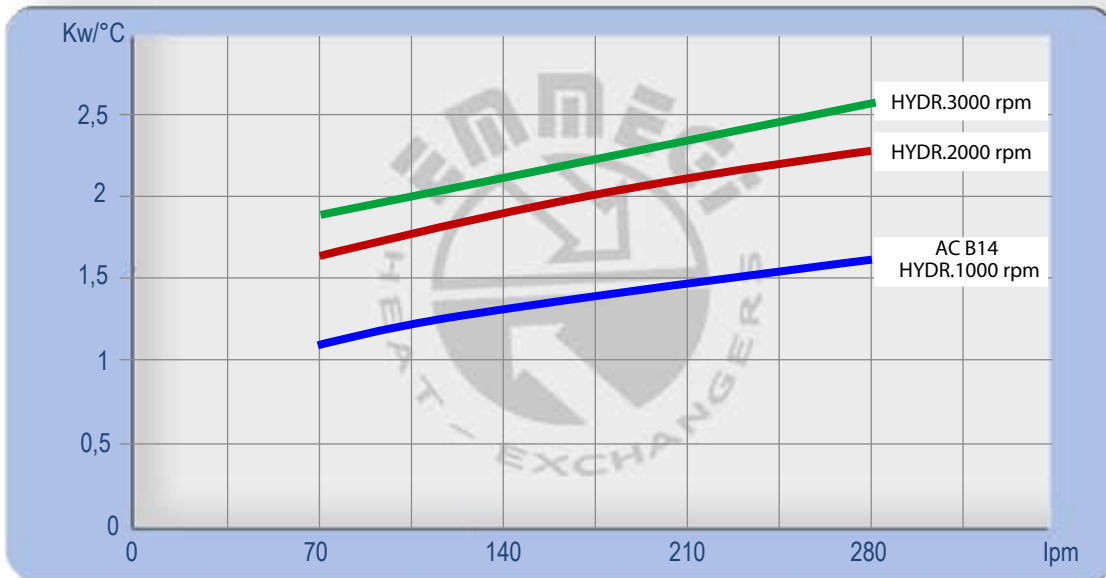

## Perdite di carico Pressure drop (32 CST)

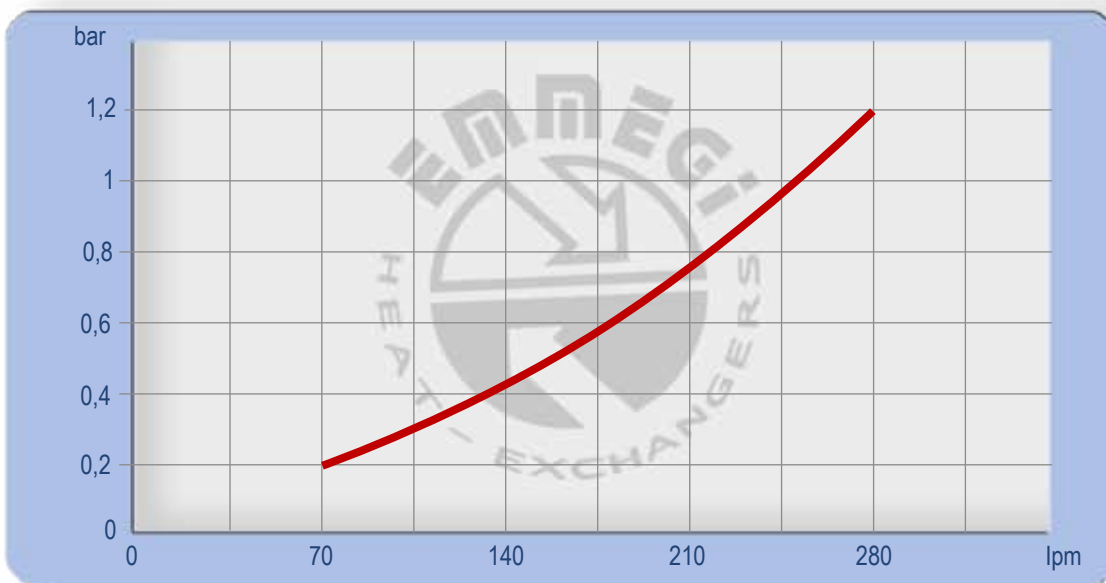

Fattore di correzione - F - (perdite di carico) Correction factor - F - (Pressure drop)

cst	10	15	20	30	40	50	60	80	100	200	300
F	0,5	0,65	0,77	1	1,2	1,4	1,6	1,9	2,1	3,3	4,3



## USA

### EMMEGI HEAT EXCHANGERS Inc.

(Main Office and Manufacturing)  
3606 E. Southern Ave. Suite 2  
Phoenix, AZ 85040 USA  
Ph. +1 602 438 7101  
Fax + 1 602 438 7127  
<http://www.emmegiinc.com>  
[sales@emmegiinc.com](mailto:sales@emmegiinc.com)

## CHINA

### EMMEGI HEAT EXCHANGERS

(Beijing) Co.,Ltd.  
Unit 706,7/ F. Building A, China  
Foreign Language Mansion,  
89 West, 3 rd Ring (N) Road,  
Haidian District,Beijing,  
PR.China,Post code: 100089  
Ph. + 86 10 88820971- Fax + 86 10 88820972  
<http://www.emmegi-heat-exchangers.com>  
[emmegi@vip.sina.com](mailto:emmegi@vip.sina.com)

## SWEDEN/FINLAND

### EMMEGI HEAT EXCHANGERS

NORDIC AB.  
Box 1136  
262 22 ANGELHOLM  
Visitors: Nybrovagen 4  
Ph. + 46 (0) 431- 415096  
Fax + 46 (0) 431- 415099  
<http://www.emmegi-heat-exchangers.com>  
[info.nordic@emmegi-heat-exchangers.com](mailto:info.nordic@emmegi-heat-exchangers.com)

## UK

### EMMEGI UK

(Sales Office)  
Evergreen, The Reddings  
Cheltenham GL51 6RL  
Ph. + 44 1242700151  
Fax + 44 8707577659  
<http://www.emmegi.co.uk>  
[sales@emmegi.co.uk](mailto:sales@emmegi.co.uk)

## BRAZIL

### EMMEGI BRAZIL

(Sales Office)  
Rua Arno Luckow 61  
Bairro Gloria - Joinville - SC - Brazil  
89.217 - 211  
Ph. +55-47-3422-1903  
Mobile +55-47-9971-1763  
<http://www.emmegi-heat-exchangers.com>  
[paulob@emmegi-heat-exchangers.com](mailto:paulob@emmegi-heat-exchangers.com)

## ASIA / PACIFIC

### EMMEGI HEAT EXCHANGERS Ltd

Unit 17.9/ F.Corporation Park,  
11 On Lai Street, Siu Lek Yuen,  
Shatin, Hong Kong  
Ph. + 852-26473488- Fax + 852-26032119  
<http://www.emmegi-heat-exchangers.com>  
[emmegi@biznetvigator.com](mailto:emmegi@biznetvigator.com)

## GERMANY

### EMMEGI GmbH

-Wärmetauscher-  
Am Hagelkreutz 13 - D 41469 Neuss  
Ph. +49 213778720 - Fax +49 2137787229  
[vertrieb@emmegi-gmbh.de](mailto:vertrieb@emmegi-gmbh.de)  
<http://www.emmegi-gmbh.de>

## SLOVAKIA

### EMMEGI HEAT EXCHANGERS s.r.o.

Ul. M.Razusa 1  
95514 Topolcany  
Ph. + 421 387629212 - Fax + 421  
387629222  
<http://www.emmegi-heat-exchangers.com>  
[sro@emmegi-heat-exchangers.com](mailto:sro@emmegi-heat-exchangers.com)

## ITALIA

### EMMEGI S.p.A.

Via Newton,52 - Zona Industriale  
20062 Cassano d'Adda (MI) - Italy  
Tel. +39 0363 360236 - Fax + 39 0363 360230  
<http://www.emmegi-heat-exchangers.com>  
[info@emmegi-heat-exchangers.com](mailto:info@emmegi-heat-exchangers.com)

